

systemtronic
EMOTIONS & SOLUTIONS

We create solutions, we inspire emotions

systemtronic

Since 1988 Systemtronic has been manufacturing auxiliary contemporary furniture and developing solutions to cover pending needs of homes and facilities. Systemtronic is synonymous with quality, design, flexibility and excellence. Our products are manufactured entirely in Europe, certified by AIDIMME and committed to the environment. The brand has a range of attractive complements, including tasteful timeless pieces with practical details and finishes that combine in multiple spaces. Systemtronic continues reinventing itself. By observing the market and listening to customer's needs, products are adapted to the demand, developing and offering new solutions. Our team is dynamic, close and committed, and offering an easy communication to the client, providing personalized attention and excellent after-sales service.

Desde 1988 Systemtronic fabrica mobiliario contemporáneo auxiliar y desarrolla soluciones pendientes por cubrir en el hogar e instalaciones. Systemtronic es sinónimo de calidad, diseño, flexibilidad y excelencia. Nuestros productos son fabricados 100% en Europa, certificados por AIDIMME y comprometidos con el medioambiente. Ofrecemos complementos con apariencia atractiva, piezas de buen gusto y atemporales, con detalles prácticos y acabados que combinan en cualquier espacio. Systemtronic no deja de reinventarse. Observamos y escuchamos las necesidades del mercado y del cliente para adaptar nuestros productos según la demanda, desarrollando y aportando nuevas soluciones. El colectivo de Systemtronic es dinámico, cercano y comprometido, y facilita la comunicación con el cliente brindando una atención personalizada y un servicio de posventa excelente.

A whole world of

systemtronic

Systemtronic's products have been included in the interior design of countless projects around the world.

Los productos de Systemtronic han sido incluidos en el interiorismo de numerosos proyectos alrededor del mundo.

These are some of the architecture studios we have worked with:

Estos son algunos de los estudios de arquitectura con que hemos trabajado:

GCA Architects, David Chipperfield Architects, De Planta & Associés Architectes, Fokkema & Partners Architecten, Fran Silvestre Arquitectos, CBRE, BAROZZI VEIGA, Herzog & de Meuron, IA Interior Architects, RBTA – Ricardo Bofill Taller de Arquitectura.

These are some of our final clients:

Entre nuestros clientes finales están:

Amazon, Amorepacific Corporation, Banco Sabadell, BBVA, Google, Berghotel Maibrunn, BNP Paribas, Cartier, Facial Clinique, Firmdale Hotels, La Casa Agency, ILUNION Hotels, La Caixa, Apple, Hotel Sixtytwo, AXA, Palau de Congressos de Catalunya, Meliá Hotels & Resorts, Rumailah Hospital, Mohammed VI Polytechnic University, Palma Sport & Tennis Club, Hipotels, Caroll, H10 Hotels, Novartis.

Australia

Austria

Belgium

Canada

Chile

Czech Republic

Ecuador

Faroe Islands

Finland

France

Germany

Greece

Holland

Hong Kong

India

Ireland

Israel

Italy

Japan

Korea

Kuwait

Lebanon

Luxembourg

Morocco

Norway

Poland

Portugal

Puerto Rico

Réunion Island

Russia

Slovenia

Spain

Sweden

Switzerland

Tunisia

United Arab Emirates

United Kingdom

United States

30 years of timeless emotions

FERNANDO GIL, CEO



Systemtronic have been present in the market for over 30 years due to the hard work and effort on satisfying the needs of those who acquire our products, in an increasingly competitive, changing and demanding environment.

If society evolves, so do we, without forgetting our essence: at Systemtronic we create solutions and inspire emotions. Our catalogue caters for all types of spaces and functions, and includes products from very talented designers, as well as key elements developed within the office.

Our daily challenge is the quality of the offered products, that's why we work actively in the training of our employees, in addition to keeping an thorough control of the manufacturing processes in order to find their critical points and apply on them continuous improvement.

La permanencia de Systemtronic en el mercado durante más de 30 años está avalada por el trabajo y el esfuerzo que ponemos en satisfacer las necesidades de las personas que adquieren nuestros productos, en un ambiente cada vez más competitivo, cambiante y exigente. Si la sociedad evoluciona, nosotros también, sin olvidar jamás nuestra esencia: en Systemtronic creamos soluciones e inspiramos emociones.

Nuestro catálogo cada vez más se adecúa a todo tipo de espacios y funciones e incluye productos de diseñadores muy talentosos, así como los que desarrollamos dentro de la propia oficina.

Nuestro reto diario es la calidad del producto que ofrecemos, para lo cual trabajamos de forma activa en la formación de nuestros empleados, además de llevar un control exhaustivo de los procesos de fabricación con el fin de encontrar sus puntos críticos y ejercer sobre ellos una mejora continua.

What moves you at 30?

Auxiliary furnitures



Hold 14



Hold Daily 18



Ben 24

Separators



Malva 30



Parban 36

Tables



Celes 42



Mill 52



Laura 56

Plant pots



Green Cloud 60

Green Cloud Peg 66



Green Light 72

Green Light wall 78

Family products



Crepe plant pot 84

Crepe umbrella stand 90

Crepe umbrella stand L 92



Conee plant pot 98

Conee pouf 104

Conee umbrella stand 106

Conee paper bin 108

Paper bins



Drop 114



Drop Top 118



Drop Top Triple 124



Drop Top Mini 130

Umbrella stands



Drop Out 136



Sou 140



Forrein 144

Coat racks



Naname 148



Second Tree 152



Second Tree Wall 156



Ker 160



Elica 164



Elica Mini 166



Branch 168



Inlin 172



Imper 176



Cantha 178



Pointo 182



Climb 186



Buraco 190

Find your product

Television accessories



SITA 192

Sitabo 198

Clock



Nube 204

Bookshelves



Baldas 206



Usio 210

Magazine racks



Koku 214



Mott 216



Zin 218

Fire extinguisher support



Faya 220

Ashtray



Fum 224

Tensabarrier



Trec 228

Exhibitors



Lit 230



Flap 232



Modulor 234



Iflag 236



Atria 238

Office tables



Foork 244



Naski 250

Office accessories



Store 252

Office set 256

It's up to you finishes, colors... 264

**When the
product
becomes
art**

**When
art inspires
spaces**



Bench and wardrobe belonging to the Wing collection. For more information, consult the Wing catalogue.
Banco y armario pertenecientes a la colección Wing. Para más información, consultar catálogo Wing.

Hold

Due to its design and functionality, this auxiliary element fits perfectly into multiple spaces: bedrooms, kitchens, bathrooms, offices... Manufactured in folded steel sheet and coated with oven thermoset powder paint.

Elemento auxiliar que gracias a su diseño y funcionalidad encaja perfectamente en múltiples espacios: habitaciones, cocinas, baños, oficinas... Fabricado en plancha de acero plegada y recubierta con pintura en polvo termoendurecida al horno.



Hold by Aranda Aloy Enblanc

Hold

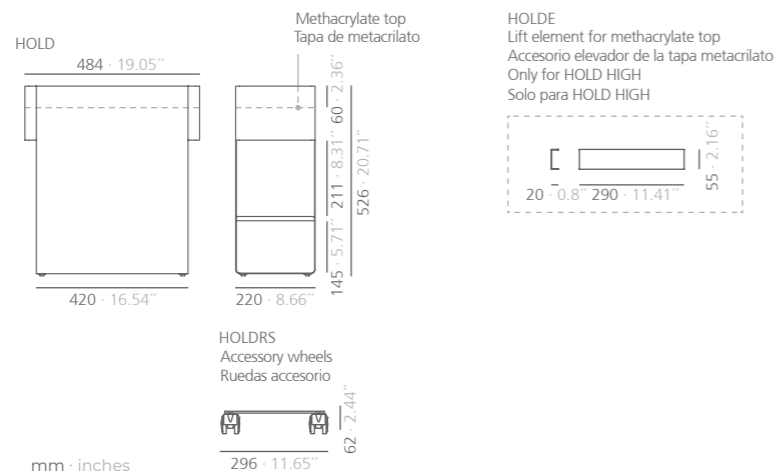
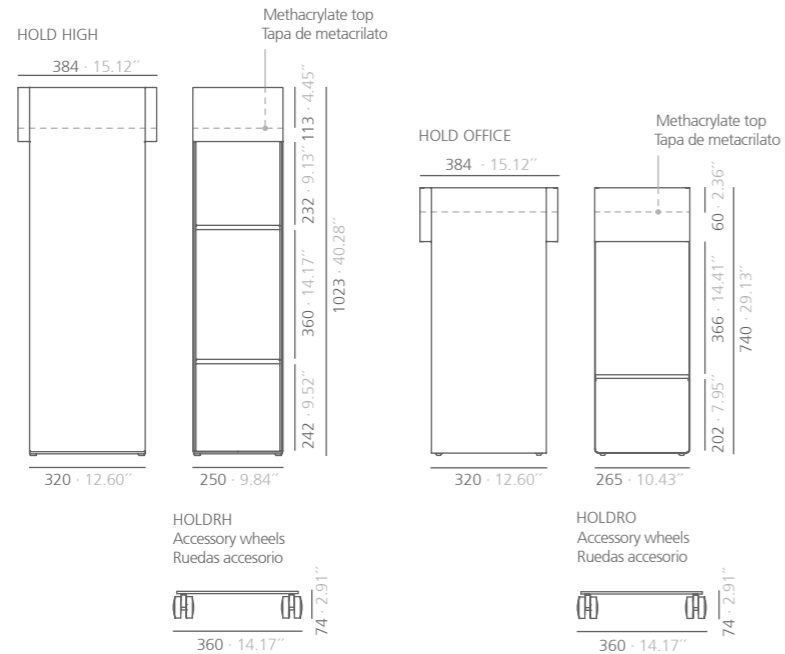

**Fits into
multiple spaces**

by ARANDA ALOY ENBLANC

Aranda Aloy Enblanc
develops projects in the
field of **Industrial Design,**
Graphic Communication
and design of spaces.

Aranda Aloy Enblanc
desarrolla proyectos
en el ámbito del
Diseño Industrial, la
Comunicación Gráfica y el
diseño de espacios.



Hold by Aranda Aloy Enblanc

Hold Daily

Auxiliary furniture specific for workspaces. It's closed at the back side. It has a great capacity and movement facility thanks to its casters of 64mm of diameter.

Available in two versions: Hold Daily DR with door and locker or Hold Daily BX without door. The box is offered as an option. Manufactured in folded steel sheet and coated with oven thermoset powder paint.

Mueble auxiliar específico para espacios de trabajo. Cerrado por detrás, con gran capacidad y facilidad de movimiento gracias a sus ruedas especiales de 64mm de diámetro.

Disponible en dos versiones: Hold Daily DR con puerta y cerradura o Hold Daily BX sin puerta. Se ofrece el cajón de forma opcional. Fabricado en plancha de acero plegada y recubierta con pintura en polvo termoendurecida al horno.

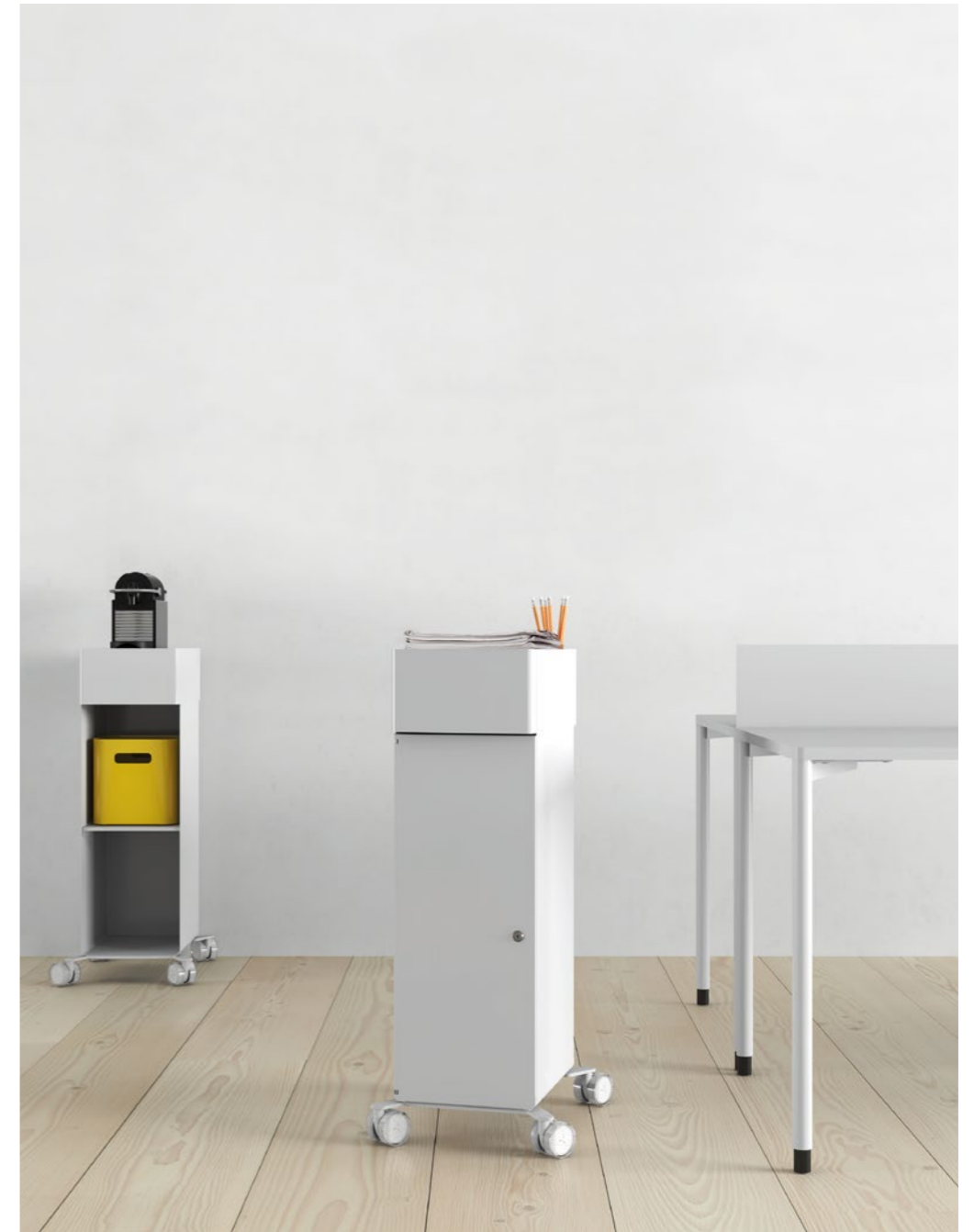



Hold Daily

HOLD DAILY DR

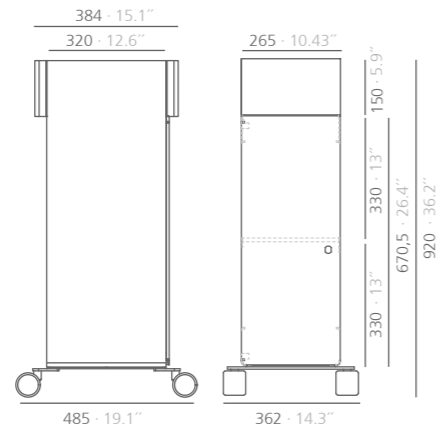

HOLD DAILY BX

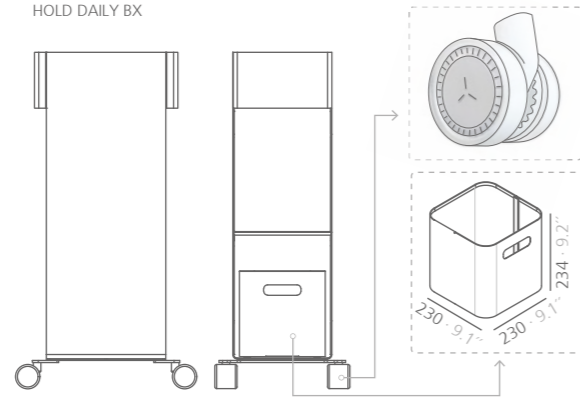

mm · inches



It can be
whatever
you want

by ARANDA ALOY ENBLANC

Aranda Aloy Enblanc develops projects in the field of Industrial Design, Graphic Communication and design of spaces.

Aranda Aloy Enblanc desarrolla proyectos en el ámbito del Diseño Industrial, la Comunicación Gráfica y el diseño de espacios.



Hold Daily by Aranda Aloy Enblanc

Ben

“The object of art is not to represent the outward appearance of things”





Ben

Ben, versatile, compact auxiliary furniture, with easy mobility and displacement. It stands out for the dimension of its wheels finished in natural oak and its solid natural oak wood knob. Made of steel and coated with oven thermoset powder paint.

Ben, mueble auxiliar versátil, compacto, de fácil movilidad y desplazamiento. Destaca por la dimensión de sus ruedas acabadas en roble natural y su pomo de madera maciza de roble natural. Fabricado en acero y pintado con pintura en polvo termoendurecida lacada al horno.

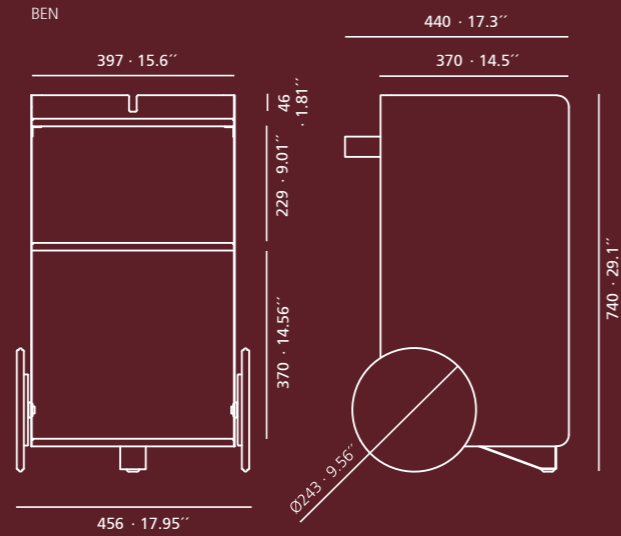

mm · inches



**Easy mobility
Compact**

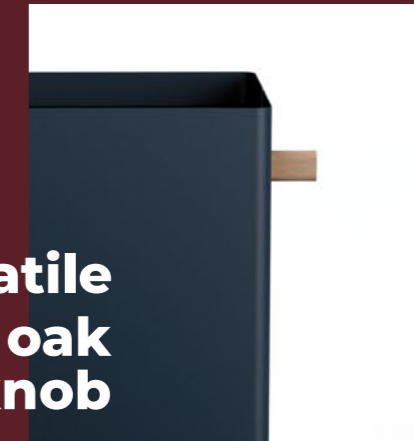

**Versatile
Natural oak
wheels and knob**

by ARANDA ALOY ENBLANC

Aranda Aloy Enblanc develops projects in the field of Industrial Design, Graphic Communication and design of spaces.

Aranda Aloy Enblanc desarrolla proyectos en el ámbito del Diseño Industrial, la Comunicación Gráfica y el diseño de espacios.



Ben by Aranda Aloy Enblanc

Malva

The forms of the Malva space divider emerge inspired by the waves of the sea, a place where you can switch-off and enjoy a moment of tranquility. The Malva is versatile and adaptable to a great variety of environments. Available in different colors and sizes.

Las formas del separador de ambientes Malva surgen de la inspiración en las olas del mar, un lugar donde desconectar y buscar un momento de tranquilidad. El separador Malva es versátil y adaptable a una gran variedad de ambientes. Disponible en diferentes acabados y tamaños.

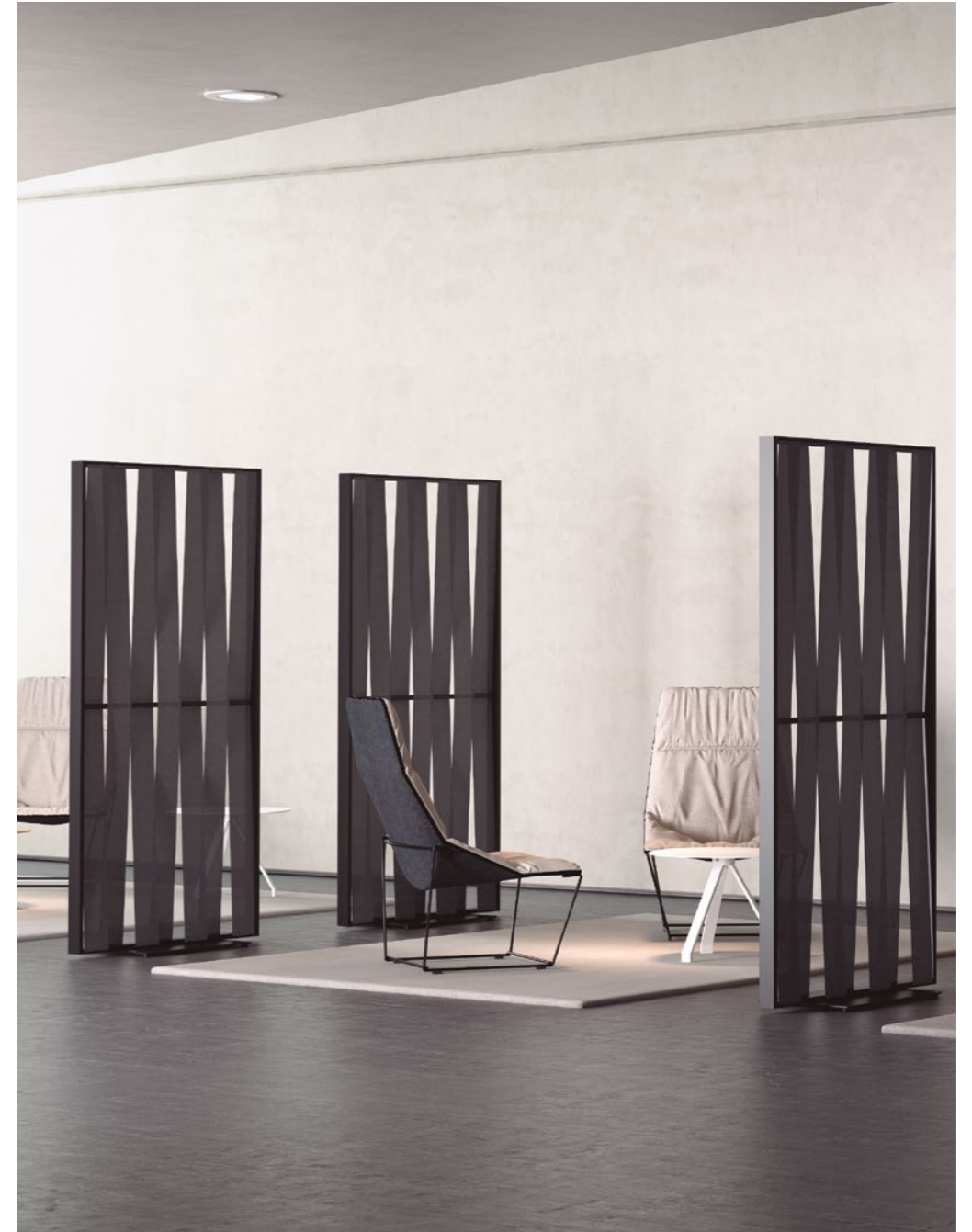

Malva by Hugo Tejada



Malva



mm · inches



Room divider
Turning single-use rooms
into multiple spaces

by HUGO TEJADA

Spanish designer who has collaborated with various companies related to lighting and furniture products.

Diseñador español que ha colaborado con diversas empresas relacionadas con productos de iluminación y mobiliario.



Parban



Elegant and minimalist room divider with oak feet, composed by a rectangular structure of triangular section which frames an aluminum mesh. Available in different colors and sizes.

Elegante y minimalista separador de ambientes con pies de roble, compuesto por una estructura rectangular de sección triangular que enmarca una malla de aluminio. Disponible en diferentes colores y tamaños.

Parban



Parban

PARBAN_L

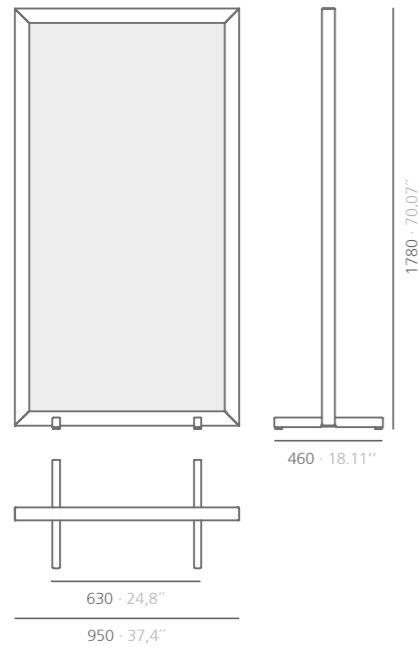

PARBAN_S

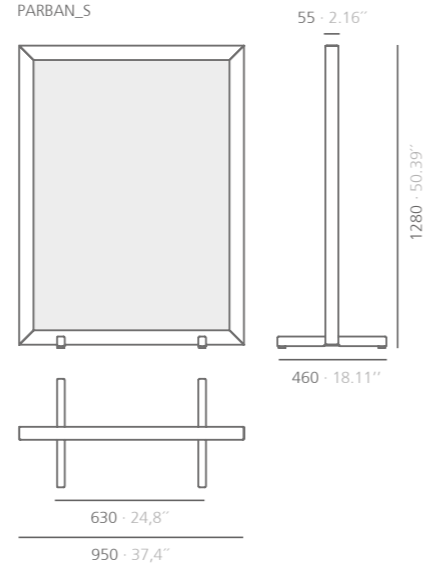

mm · inches



Same space,
many interiors

Who needs walls
when you have Parbans?

by VÍCTOR CARRASCO

Víctor Carrasco, strategic director of Viccarbe, has developed and positioned international brands with remarkable added value, thanks to his passion for synthesis and sustainable growth.

Víctor Carrasco, director estratégico de Viccarbe, desarrolla y posiciona marcas internacionales con un sorprendente *added value* gracias a su fijación por la síntesis y los crecimientos sostenibles.



Parban by Víctor Carrasco

Celes

Outdoor / Indoor



Set of tables of different heights and board sizes, combinable with each other, made entirely in aluminum and suitable for outdoor use.

Conjunto de mesas a diferentes alturas y tamaños de tablero combinables entre sí, fabricadas íntegramente en aluminio, aptas para su uso en exterior.

Celes by Víctor Carrasco



Celes

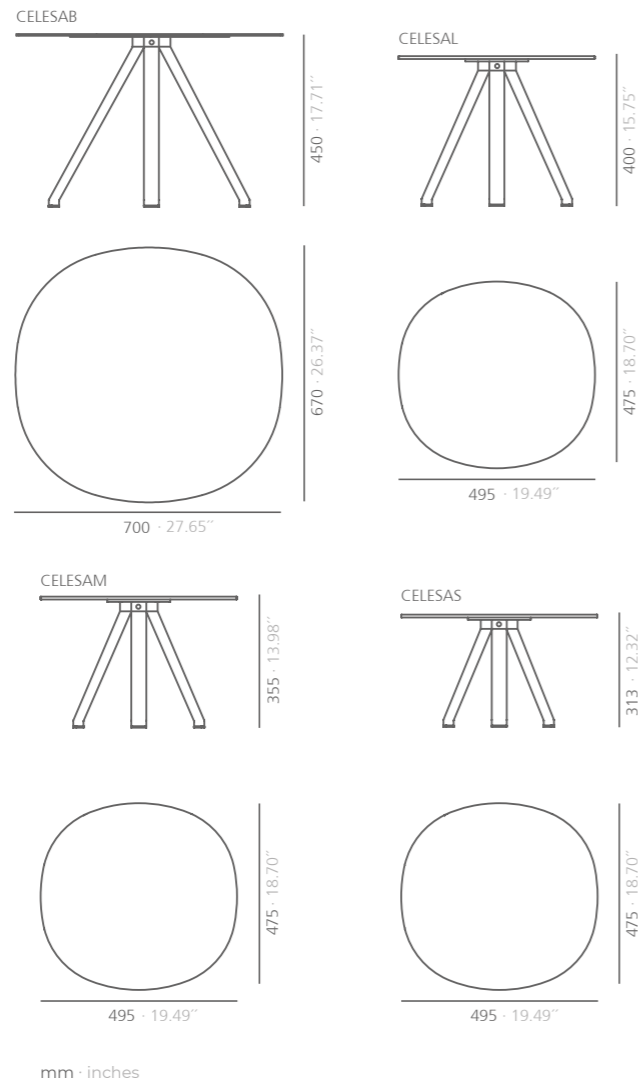

Outdoor / Indoor



Different sizes and finishes

Combinable with each other

by VÍCTOR CARRASCO

Víctor Carrasco, strategic director of Viccarbe, has developed and positioned international brands with remarkable added value, thanks to his passion for synthesis and sustainable growth.

Víctor Carrasco, director estratégico de Viccarbe, desarrolla y posiciona marcas internacionales con un sorprendente *added value* gracias a su fijación por la síntesis y los crecimientos sostenibles.



Celes by Víctor Carrasco

Celes

Indoor



Version of Celes table for interiors,
with steel tube legs and MDF
tabletop finished in natural oak
or HPL white or black.

Versión de mesas Celes para interior
con patas de tubo de acero y tablero
MDF acabado en roble natural o HPL
blanco o negro.

Celes

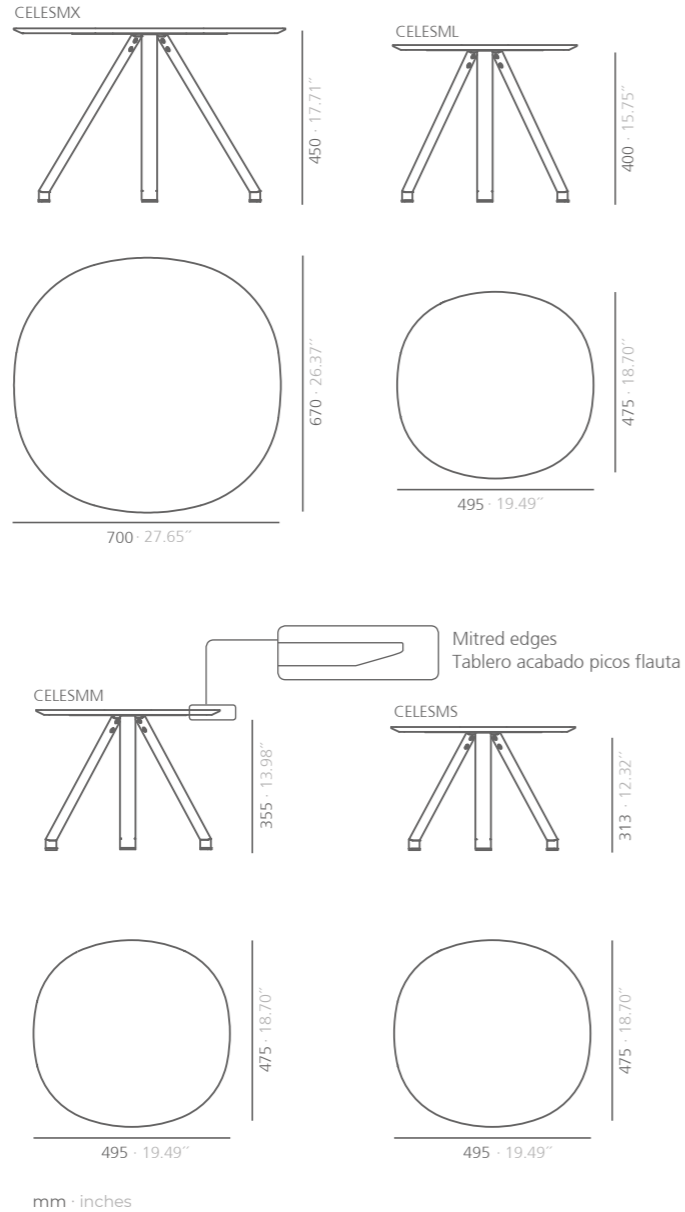

Indoor



Different sizes and finishes

Combinable with each other

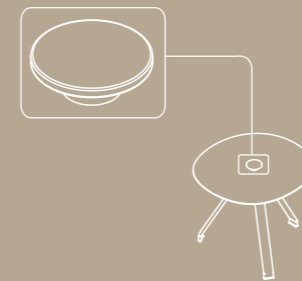

CELESPOM
Optionally, an oak central handle can be added to the indoor Celes table for easy movement.

De forma opcional, se le puede añadir a la mesa Celes de interior un asa central de roble que ayuda a su desplazamiento.

by VÍCTOR CARRASCO

Víctor Carrasco, strategic director of Viccarbe, has developed and positioned international brands with remarkable added value, thanks to his passion for synthesis and sustainable growth.

Víctor Carrasco, director estratégico de Viccarbe, desarrolla y posiciona marcas internacionales con un sorprendente *added value* gracias a su fijación por la síntesis y los crecimientos sostenibles.



Mill

The tabletops of this collection are available in lacquered MDF or transparent tempered glass with 10mm of thickness that combine with two versions of bases.

Los sobres de esta colección de mesas están disponibles en MDF lacado o cristal templado transparente de 10mm de espesor que combinan con dos versiones de bases.



Mill

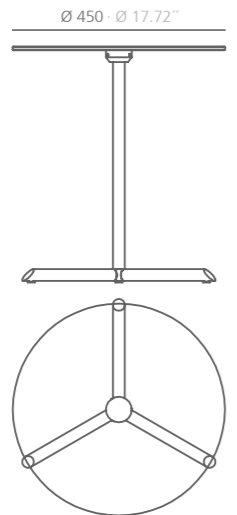

MIYC
Glass top and "Y" base
Sobre de cristal y base "Y"

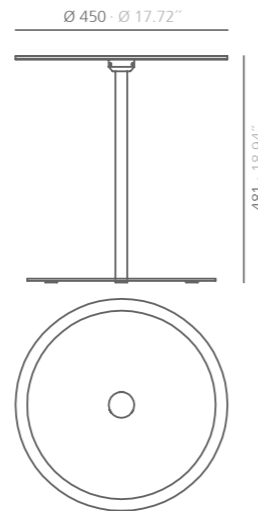

MIOC
Glass top and base "O"
Sobre de cristal y base "O"

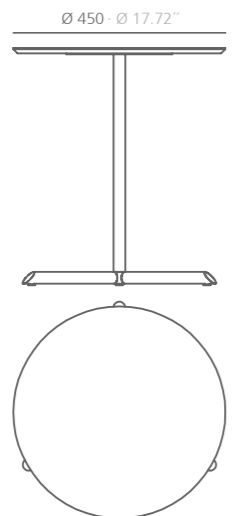

MIYM
Laquered MDF top and "Y" base
Sobre de MDF lacado y base "Y"

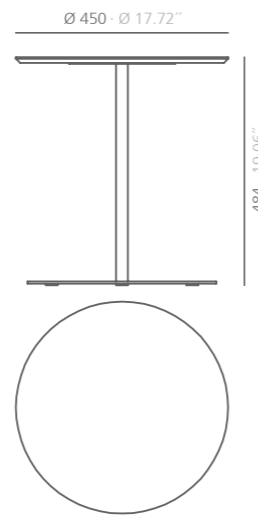

MIOM
Laquered MDF top and "O" base
Sobre de MDF lacado y base "O"

mm · inches



**Different tops,
different bases,
you decide**



**STC Studio is part of
the product design and
development department
of Systemtronic,
integrated by a group of
professionals with a wide
experience in the sector.**

STC Studio forma parte del departamento de diseño y desarrollo de producto de Systemtronic, compuesto por un grupo de profesionales con amplia experiencia en el sector.

by STC STUDIO

Mill by STC Studio

Laura



Laura is a versatile and functional table. This side table has so many possibilities as you can imagine. It has a container that can be used as a plant pot or store.

Laura es una mesa versátil y funcional. Tiene tantas posibilidades como puedas imaginarte. Cuenta con un contenedor que puede servir de macetero o para guardar objetos.

Laura

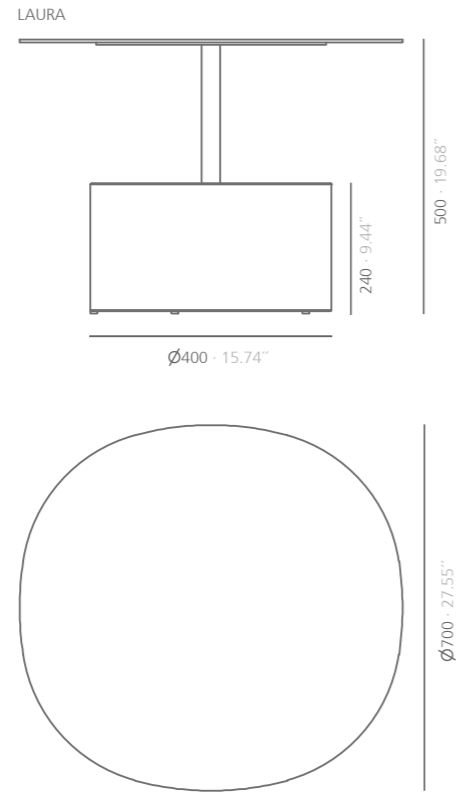

mm · inches



As many possibilities
as you can imagine

Versatile and
multipurpose

by MERMELADA ESTUDIO

Mermelada Estudio is an international product design studio. They work with ideas, giving a special importance to the conceptual and formal investigation.

Mermelada Estudio es una firma centrada en el diseño industrial. Trabajan con ideas, dando una especial importancia a la investigación conceptual y formal.



Laura by Mermelada Estudio

Green Cloud

The design of this plant pots evokes lamps emitting vegetation. Manufactured in aluminum and steel. They include a plastic saucer.

El diseño de estos maceteros evoca lámparas que emiten vegetación. Fabricados en aluminio y acero. Incluyen un plato de plástico.



Green Cloud by Mermelada Estudio



Green Cloud

GREEN LIGHT_L

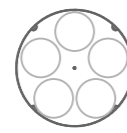
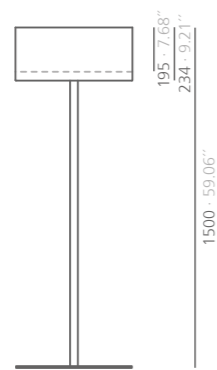

Ø 515 · Ø 20.28"

GREEN LIGHT_M

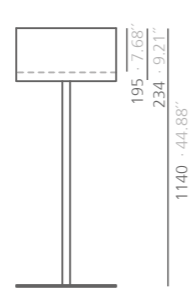

Ø 440 · Ø 17.32"

GREEN LIGHT_S

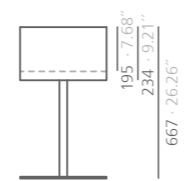

Ø 380 · Ø 14.96"

GREEN CLOUD_L

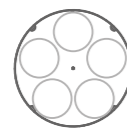
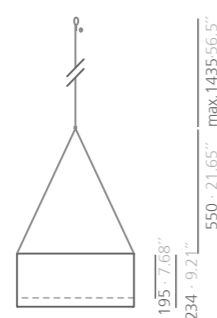

Ø 515 · Ø 20.28"

GREEN CLOUD_M

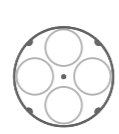
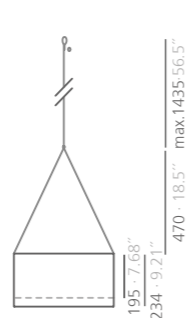

Ø 440 · Ø 17.32"

GREEN CLOUD_S

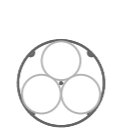
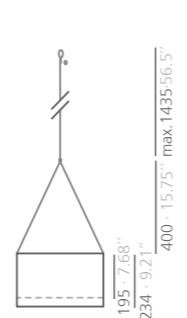

Ø 380 · Ø 14.96"

mm · inches



More than planters, Art Lamps emitting vegetation

Do not add soil directly to the Green Cloud. Must be used with internal pots. The possibility of acquiring pots of 2,8 liters is offered, allowing combinations of 3, 4 or 5 depending on the capacity of the product.

No añadir la tierra directamente al Green Cloud. Debe usarse con macetas interiores. Se ofrece la posibilidad de adquirir macetas de 2,8 litros, para combinaciones de 3, 4 o 5 en dependencia de la capacidad del producto.

by MERMELADA ESTUDIO

Mermelada Estudio is an international product design studio. They work with ideas, giving a special importance to the conceptual and formal investigation.

Mermelada Estudio es una firma centrada en el diseño industrial. Trabajan con ideas, dando una especial importancia a la investigación conceptual y formal.



Green Cloud Peg



**“Art is the only
way to run
away without
leaving home”**



Shelving belonging to the **Wing** collection. For more information, consult the Wing catalogue.
Estantería perteneciente a la colección Wing. Para más información, consultar catálogo Wing.

Green Cloud Peg

Plant pot manufactured in aluminum. It includes a plastic saucer. Ideal for outdoors. It is required to drill the ground or floor where it will be used.

Macetero fabricado en aluminio. Incluye un plato de plástico. Ideal para exteriores. Se requiere perforar el suelo o piso donde se vaya a usar.

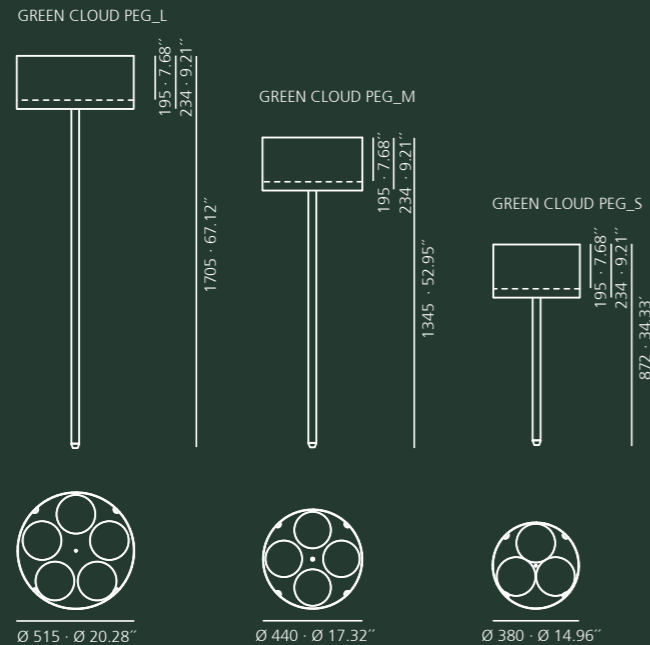

mm · inches



Be inspired by nature Design that brings life

Do not add soil directly to the Green Cloud. Must be used with internal pots. The possibility of acquiring pots of 2,8 liters is offered, allowing combinations of 3, 4 or 5 depending on the capacity of the product.

No añadir la tierra directamente al Green Cloud. Debe usarse con macetas interiores. Se ofrece la posibilidad de adquirir macetas de 2,8 litros, para combinaciones de 3, 4 o 5 en dependencia de la capacidad del producto.

by **MERMELADA ESTUDIO**

Mermelada Estudio is an international product design studio. They work with ideas, giving a special importance to the conceptual and formal investigation.

Mermelada Estudio es una firma centrada en el diseño industrial. Trabajan con ideas, dando una especial importancia a la investigación conceptual y formal.



Green Light



The design of these rectangular plant pots evokes lamps emitting vegetation. Three versions are available: hanging, desktop and wall-mounted. Manufactured in aluminum and steel.

El diseño de estos maceteros rectangulares evoca lámparas que emiten vegetación. Disponibles en tres versiones: colgante, sobremesa y a pared. Fabricados en aluminio y acero.



Green Light

GREEN LIGHT_C

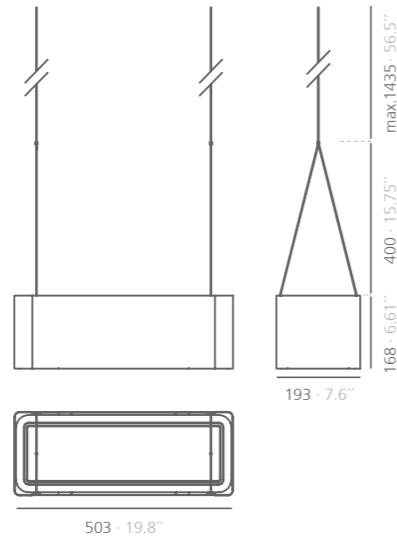

GREEN LIGHT_T

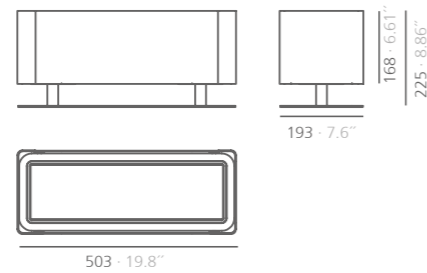

mm · inches



Lightness Unconventional planters enhance creativity

Must be included:
1 saucer and 1 window box
of 9 litres (19.69"x7.09"_h5.91").
The possibility of acquiring them is offered.

Deben incluir:
1 plato y 1 balconera de 9 litros (500x180_h150mm).
Se ofrece la posibilidad de adquirir estos productos.

by MERMELADA ESTUDIO

Mermelada Estudio is an international product design studio. They work with ideas, giving a special importance to the conceptual and formal investigation.

Mermelada Estudio es una firma centrada en el diseño industrial. Trabajan con ideas, dando una especial importancia a la investigación conceptual y formal.



Green Light

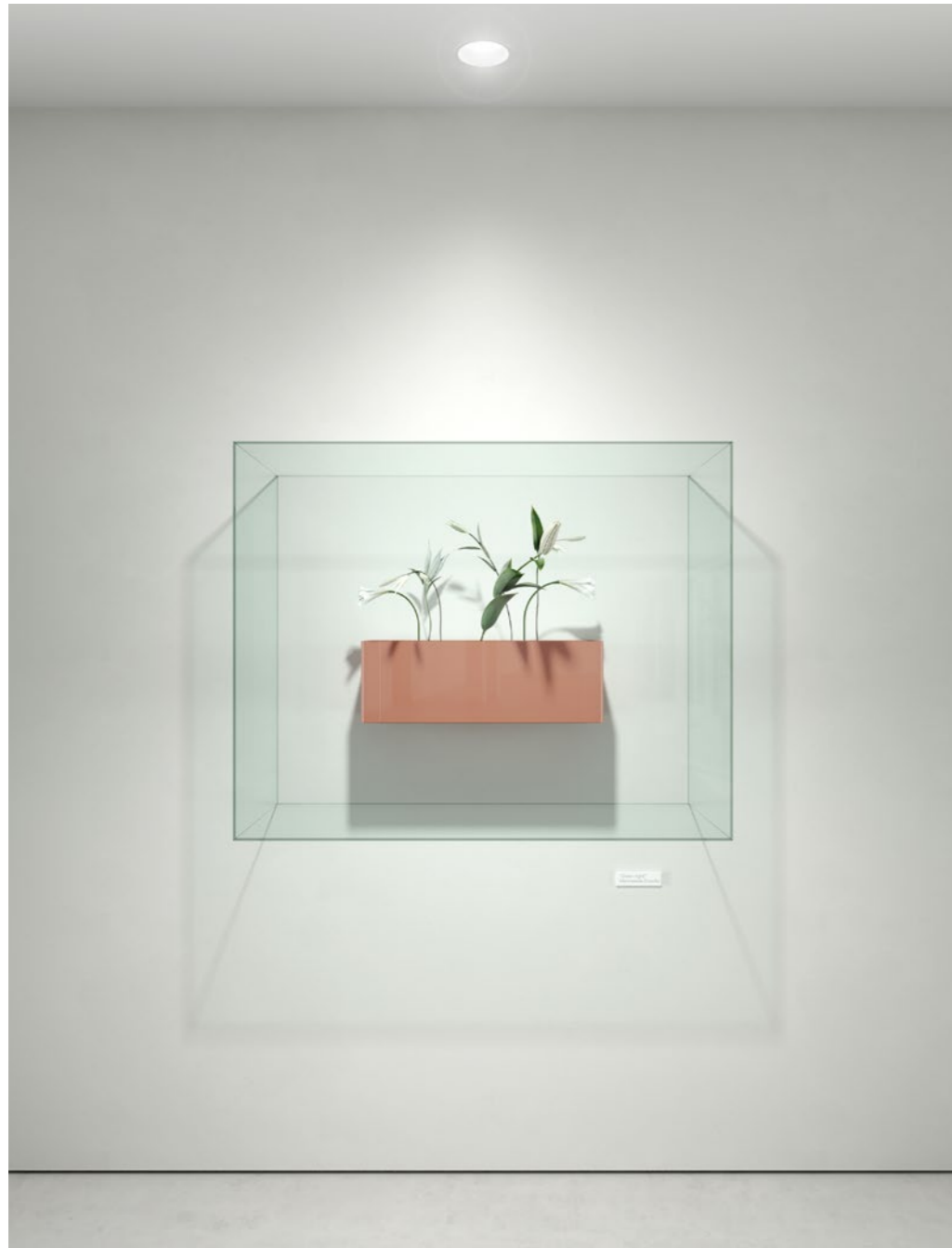

Wall

**“If ART
needs an
explanation
where is
visual”**



Green Light

The rectangular planter family Green Light is completed with this wall-mounted option. Manufactured in aluminum and steel.

El modelo de jardineras rectangulares de la familia Green Light se completa con esta opción a pared. Fabricada en aluminio y acero.

GREEN LIGHT_W

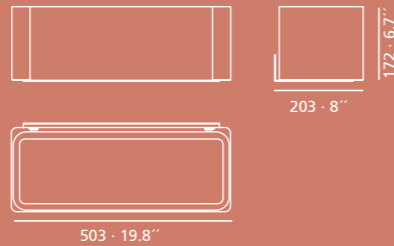

mm · inches

Wall

Hidden support
Lightness
Wall art



Must be included:
1 saucer and 1 window box
of 9 litres (19.69"x7.09"_h5.91").
The possibility of acquiring them is offered.

Deben incluir:
1 plato y 1 balconera de 9 litros (500x180_h150mm).
Se ofrece la posibilidad de adquirir estos productos.

by MERMELADA ESTUDIO

Mermelada Estudio is an international product design studio. They work with ideas, giving a special importance to the conceptual and formal investigation.

Mermelada Estudio es una firma centrada en el diseño industrial. Trabajan con ideas, dando una especial importancia a la investigación conceptual y formal.



Crepe



Plant pot

Plant pots manufactured in aluminum folded sheet and painted in different colors.

Jardineras fabricadas en plancha de aluminio plegada y pintada en diferentes colores.



Crepe

CREPE_H

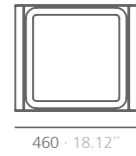
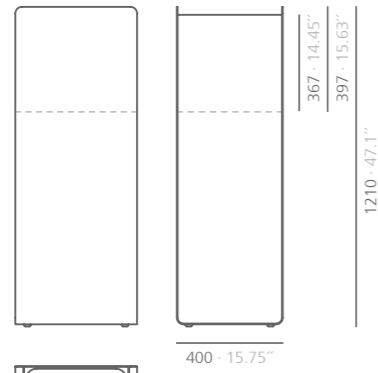

CREPE_S

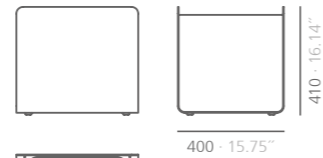

CREPE_L

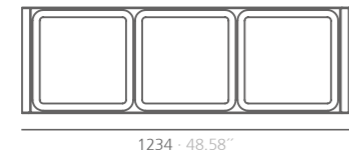
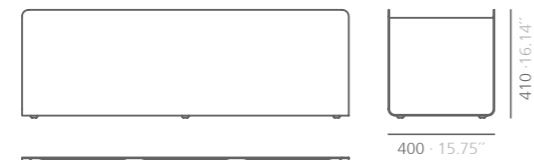

mm · inches

Plant pot



Multiple sizes
and finishes

Aluminum folded sheet

Must be included:
1 saucer & 1 plant pot of 25 liters
(14.96"x14.96" _h13.19").
The possibility of acquiring them is offered.

Debe incluir:
1 plato y 1 maceta de 25 litros
(380x380_h335mm).
Se ofrece la posibilidad de adquirir estos productos.

by VÍCTOR CARRASCO

Víctor Carrasco, strategic director of Viccarbe, has developed and positioned international brands with remarkable added value, thanks to his passion for synthesis and sustainable growth.

Víctor Carrasco, director estratégico de Viccarbe, desarrolla y posiciona marcas internacionales con un sorprendente *added value* gracias a su fijación por la síntesis y los crecimientos sostenibles.



Crepe plant pot by Víctor Carrasco

Crepe

Tasteful design



for a rainy day

Umbrella stand

Umbrella stands manufactured in aluminum folded sheet and painted in different colors. They include a grid to separate the umbrellas and a plate to collect the water.

Paragüeros fabricados en plancha de aluminio plegada y pintada en diferentes colores. Incluyen una rejilla para separar paraguas y un plato para recoger el agua.

CREPE_S_umbrella stand



mm · inches

Crepe

**“Art is not
what you
see, is
what you
make
others see”**

Umbrella stand



Crepe umbrella stand by Victor Carrasco



Crepe

The Crepe L umbrella stand has been created as a solution for large spaces. In addition to being characterized by its great capacity, it is made of aluminum, allowing its outdoor use.

Includes three dishes that collect water inside.

El paraguero Crepe L ha sido creado para dar solución a grandes espacios. Además de caracterizarse por su gran capacidad, está fabricado en aluminio, permitiendo su utilización en el exterior.

Incluye tres platos que recogen el agua en su interior.

CREPE_L_umbrella stand



400 · 15.75"

410 · 16.14"



1234 · 48.58"

mm · inches

Umbrella stand



Aluminum
Exterior use
Great capacity

Víctor Carrasco, strategic director of Viccarbe, has developed and positioned international brands with remarkable added value, thanks to his passion for synthesis and sustainable growth.

Víctor Carrasco, director estratégico de Viccarbe, desarrolla y posiciona marcas internacionales con un sorprendente *added value* gracias a su fijación por la síntesis y los crecimientos sostenibles.

by VÍCTOR CARRASCO



Crepe umbrella stand by Víctor Carrasco

Conee



Plant pot

All the Conee plant pots have a cone trunk structure with a bent axis, made of a curved aluminum sheet. They come with casters.

Todos los Conee jardinera poseen una estructura de tronco de cono con el eje inclinado, compuesta por una plancha curvada de aluminio. Lleva ruedas.



Conee

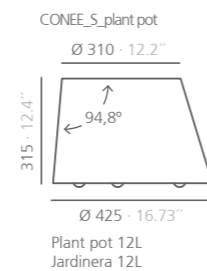
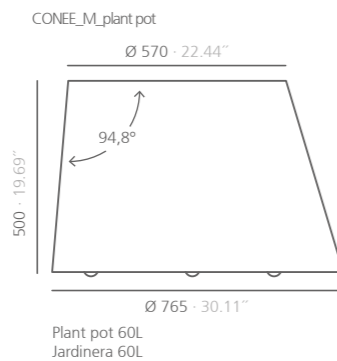
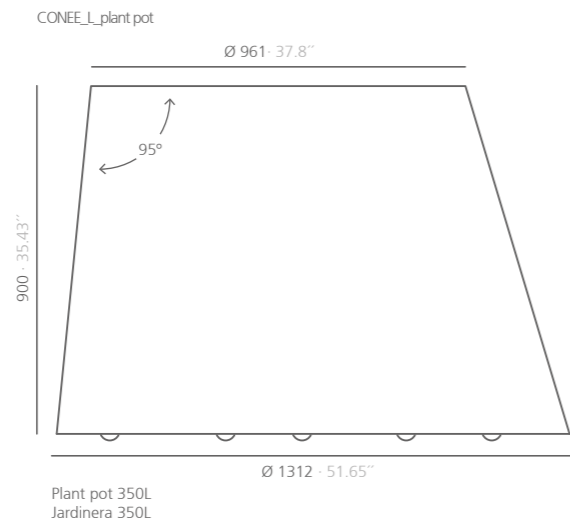

mm · inches

Plant pot



Nature-inspired
Your little garden
deserves Conees

They include a saucer and an interior pot.
Incluyen plato y macetero interior.

by VÍCTOR CARRASCO

Víctor Carrasco, strategic director of Viccarbe, has developed and positioned international brands with remarkable added value, thanks to his passion for synthesis and sustainable growth.

Víctor Carrasco, director estratégico de Viccarbe, desarrolla y posiciona marcas internacionales con un sorprendente *added value* gracias a su fijación por la síntesis y los crecimientos sostenibles.



conne plant pot by Víctor Carrasco

Conee

**Socialize
with comfort,**



**socialize
with poufs!**

Pouf

The Conee pouf has a wooden cone trunk structure with a bent axis, and it's upholstered in faux leather. It comes with 5 casters.

El Conee puf posee una estructura de madera de tronco de cono con el eje inclinado, y va tapizado en polipiel. Lleva 5 ruedas.

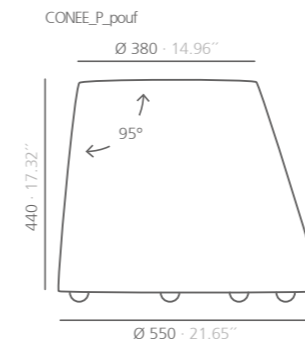

mm · inches

Conee

Love it,
feel it!



Umbrella stand

The Conee umbrella stand has a cone trunk structure with a bent axis, made of a curved sheet of aluminum. It includes an inner tubular structure that forms different departments to place the umbrellas and a plastic plate to collect the water. It comes with 3 casters.

El Conee paraguero posee una estructura de tronco de cono con el eje inclinado, compuesta por una plancha curvada de aluminio. Incluye una estructura tubular interior que forma diferentes departamentos para colocar los paraguas y un plato de plástico para recoger el agua. Lleva 3 ruedas.

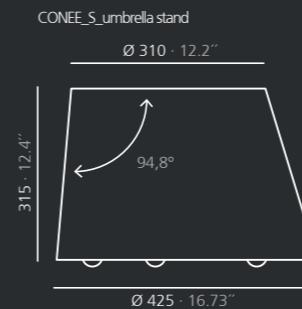

mm · inches

Conee umbrella stand by Víctor Carrasco

Conee

Make your job easier



Paper bin

The Conee paper bin has a cone trunk structure with a bent axis, made of a curved sheet of aluminum. It includes a plastic plate for greater protection against spills and an internal structure that holds the bag. It comes with 3 casters.

El Conee papelera posee una estructura de tronco de cono con el eje inclinado, compuesta por una plancha curvada de aluminio. Incluye un plato de plástico para mayor protección frente a vertidos y una estructura interior que sujeta la bolsa. Lleva 3 ruedas.

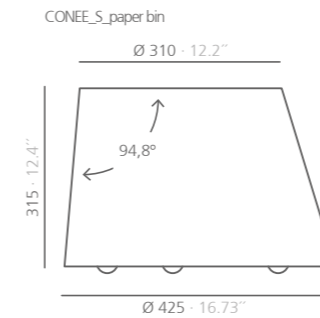

mm · inches

your restaurant
systemtronic

Don't think,

- 1-Green Cloud
Finish: Textured black RAL 9011.
- 2-Elica Mini
Finish: Matte grey beige RAL 1019.
- 3-Faya
Finish: Matte white RAL 9003.
- 4-Ben
Finish: Textured bronze bagana.
- 5-Atria
Finish: Matte grey beige RAL 1019.
- 6-Sou stand
Finish: Textured bronze bagana.



Every optimized restaurant requires clear and planned functionalities, with versatile and detailed design products. In this sense, Systemtronic offers a wide range of options under the maximum EMOTIONS AND SOLUTIONS. We also bet on easy to identify products, with a unique touch that will make the experience an unforgettable memory.

Todo restaurante optimizado requiere funcionalidades claras y planificadas, con productos versátiles y con un diseño cuidado. En este sentido, Systemtronic brinda un amplio abanico de opciones bajo la máxima EMOTIONS AND SOLUTIONS. Apostamos además por productos fáciles de identificar y con un toque único que hagan de la experiencia un recuerdo inolvidable.

say yes!

your restaurant
systemtronic

**Don't
think,**

say yes!



Drop



Paper bin that includes in its four sizes a hoop to hide the plastic bag, keeping the elegance of the element. Paper bin and hoop made of galvanized steel.

Elegante papelera que en sus cuatro tamaños incluye un aro que sujeta y ayuda a ocultar la bolsa, consiguiendo una línea limpia. Papelera y aro fabricados en acero galvanizado.

Drop

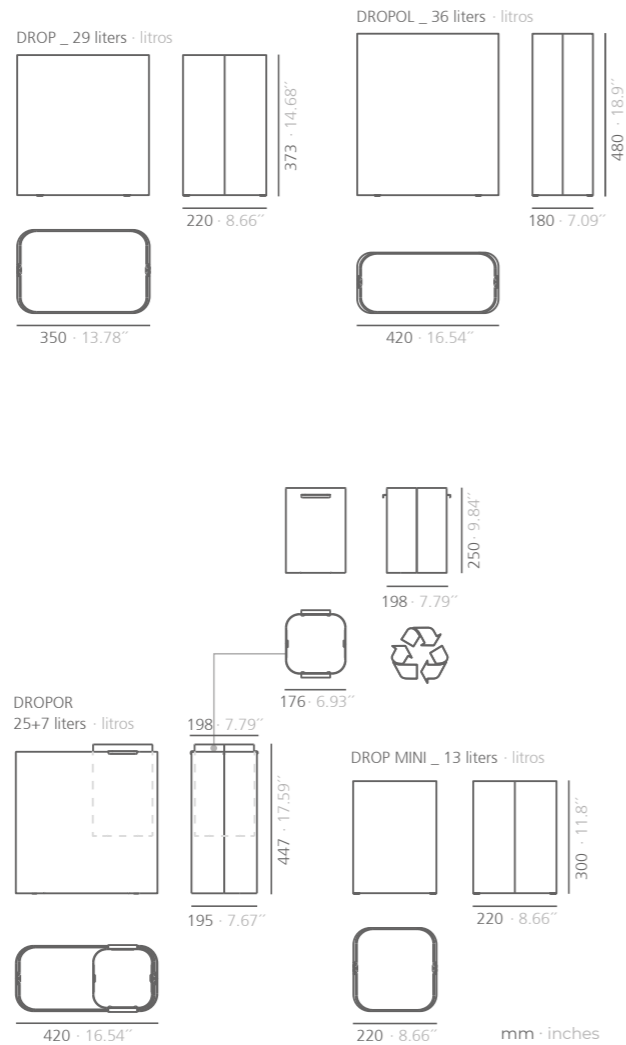

Keep it elegant

STC Studio is part of the product design and development department of Systemtronic, integrated by a group of professionals with a wide experience in the sector.

STC Studio forma parte del departamento de diseño y desarrollo de producto de Systemtronic, compuesto por un grupo de profesionales con amplia experiencia en el sector.

by STC STUDIO

Drop by STC Studio

Drop Top

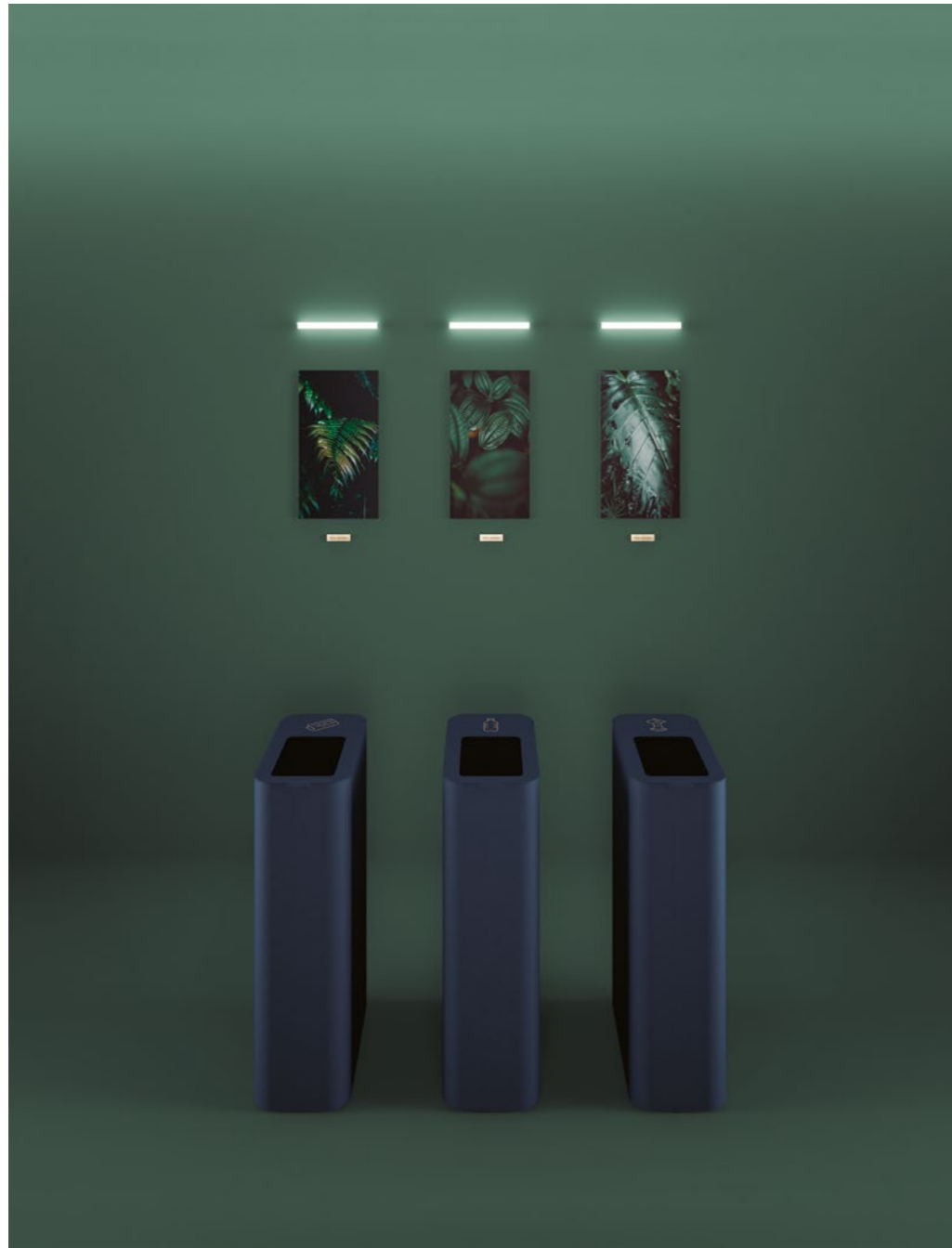

**“Vision is
the art of
seeing what
is invisible
to others”**



Drop Top

The Drop Top bin with lid partially hides waste. It is identified with a vinyl pictogram for its classification into: glass, organic, general, paper, plastic or aluminum, so that combinations of two or more bins can be made.

Manufactured in galvanized steel and coated with oven thermoset powder paint. It includes an inner ring of galvanized steel that holds the bag. The bin capacity is 62 liters. We recommend the use of garbage bags of 50 liters or more.

La papelera con tapa Drop Top oculta parcialmente los residuos. Se identifica con un pictograma vinílico para su clasificación en: vidrio, orgánico, general, papel, plástico o aluminio, de manera que puedan realizarse combinaciones de dos o más papeleras.

Fabricada en acero galvanizado y pintada con pintura en polvo termoendurecida lacada al horno. Incluye un aro interior de acero galvanizado que sujeta la bolsa. La capacidad de la papelera es de 62 litros. Recomendamos el uso de bolsas de 50 litros o más.



Half-hidden waste

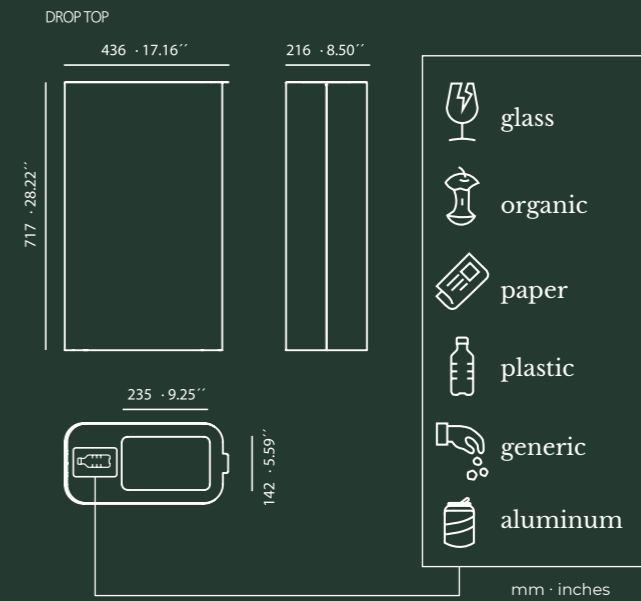

pictogram

STC Studio is part of the product design and development department of Systemtronic, integrated by a group of professionals with a wide experience in the sector.

STC Studio forma parte del departamento de diseño y desarrollo de producto de Systemtronic, compuesto por un grupo de profesionales con amplia experiencia en el sector.

by STC STUDIO

Drop top by STC Studio

Drop Top Triple

“The magical surprise of finding a lion inside a closet, where you are 'sure' to find shirts”





save the planet

Drop Top Triple

The Drop Top Triple bin allows multiple recycling in a single container thanks to its geometric shape with three compartments, differentiated on the lid.

The three cavities are identified with a vinyl pictogram to choose between: glass, organic, general, paper, plastic or aluminum. Made of galvanized steel and coated with oven thermoset powder paint. It includes an inner ring of galvanized steel that holds the bag.

The total capacity of the three cavities is 120 liters. We recommend the use of garbage bags starting from 50 liters.

La papelera Drop Top Triple permite el reciclaje múltiple en un único contenedor gracias a su forma geométrica con tres compartimentos diferenciados en la tapa.

Las tres cavidades se identifican con un pictograma vinílico a elegir entre: vidrio, orgánico, general, papel, plástico o aluminio. Fabricada en acero galvanizado y pintada con pintura en polvo termoendurecida lacada al horno. Incluye un aro interior de acero galvanizado que sujeta la bolsa.

La capacidad total de las tres cavidades es de 120 litros. Recomendamos el uso de bolsas de basura a partir de 50 litros.



**Multiple recycling
3 Compartments
Identifiable**

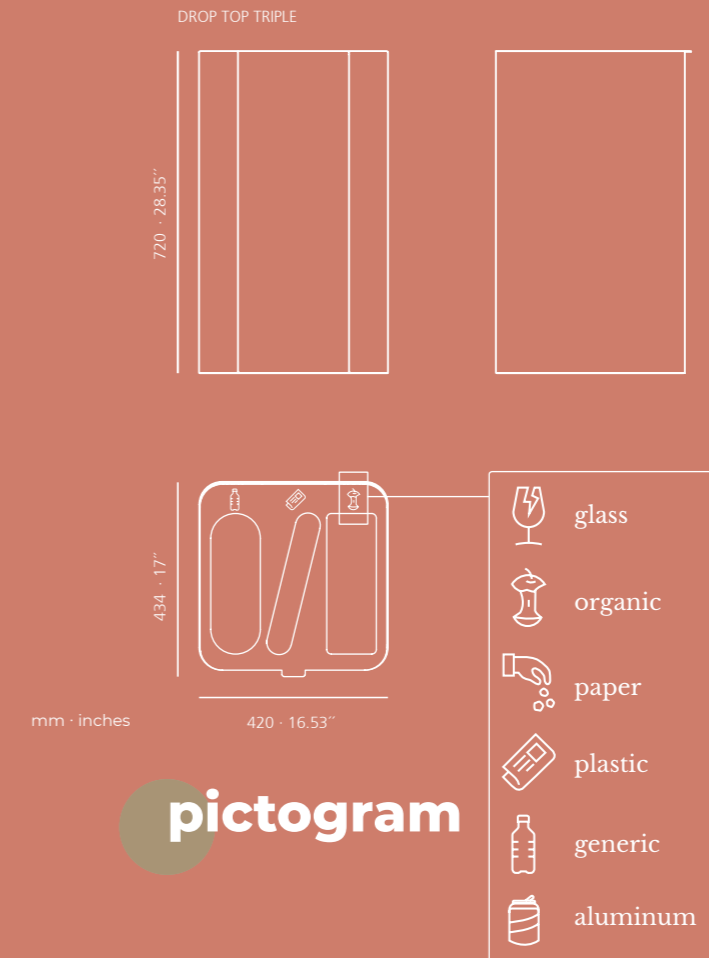

STC Studio is part of the product design and development department of Systemtronic, integrated by a group of professionals with a wide experience in the sector.

STC Studio forma parte del departamento de diseño y desarrollo de producto de Systemtronic, compuesto por un grupo de profesionales con amplia experiencia en el sector.

by STC STUDIO

Drop Top Mini

**“Without
magic there is
no art”**





Drop Top Mini

13 liter bin with lid. Made of galvanized steel and coated with oven thermoset powder paint. Like all the bin of its series, it includes a galvanized steel inner ring that holds the bag.

The use of 10 liter garbage bags is recommended.

Papelera de capacidad de 13 litros con tapa. Fabricada en acero galvanizado y pintada con pintura en polvo termoendurecida lacada al horno. Como todas las papeleras de su serie, incluye un aro interior de acero galvanizado que sujeta la bolsa.

Se recomienda el uso de bolsas de basura de 10 litros.

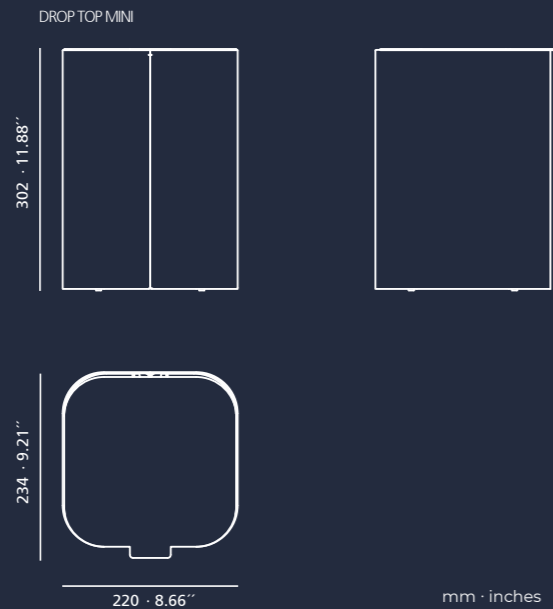

New lid!

**Mini
but with
steel soul**



STC Studio is part of the product design and development department of Systemtronic, integrated by a group of professionals with a wide experience in the sector.

STC Studio forma parte del departamento de diseño y desarrollo de producto de Systemtronic, compuesto por un grupo de profesionales con amplia experiencia en el sector.

by STC STUDIO

Drop Top Mini by STC Studio

Drop Out



Singular umbrella stand made of galvanized steel sheet with two separate buckets, one for long umbrellas and another bucket for folding ones. The colors of both can be combined.

Original paraguero de plancha de acero galvanizado con dos cubetas independientes, una destinada a los paraguas largos y otra cubeta para los plegables. Se pueden combinar los colores de ambas.

Drop Out

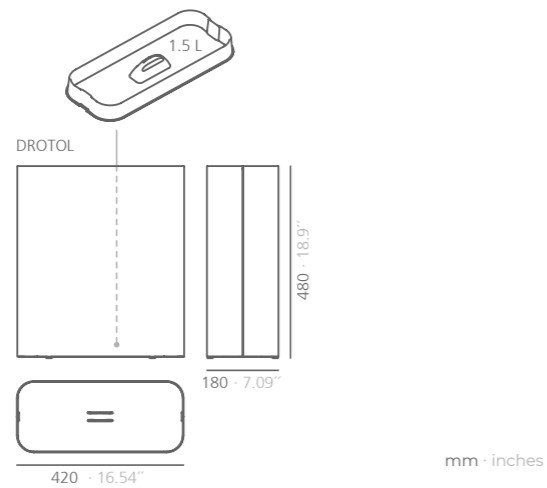
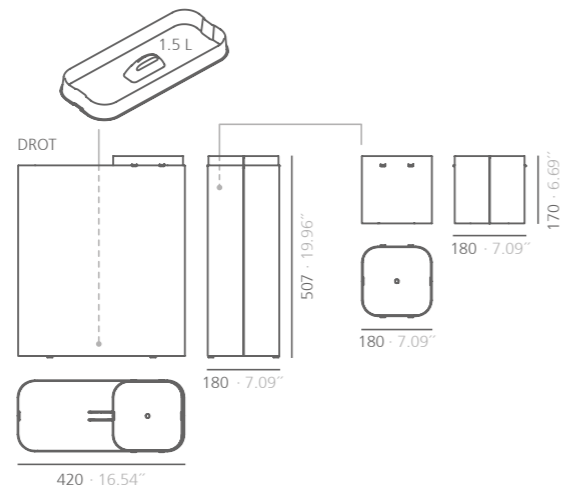

Choose your color combination

No matter the umbrella sizes, it has two buckets

STC Studio is part of the product design and development department of Systemtronic, integrated by a group of professionals with a wide experience in the sector.

STC Studio forma parte del departamento de diseño y desarrollo de producto de Systemtronic, compuesto por un grupo de profesionales con amplia experiencia en el sector.

by STC STUDIO

Drop Out by STC Studio

Sou



Umbrella stand composed by three painted steel panels, thought-out for either big or small umbrellas. Two versions are available: standing or on the wall. The base and the middle panel can be painted in a second color. It has interior cups made of aluminum for water collection.

Paragüero compuesto de 3 planos de acero pintados, pensado para paraguas tanto grandes como pequeños. Dos versiones disponibles: de pie y a pared. El acabado puede personalizarse pintando la base y el panel intermedio de un segundo color. Dispone de cazoletas interiores fabricadas en aluminio para la recogida de agua.

Sou

SOU_STAND

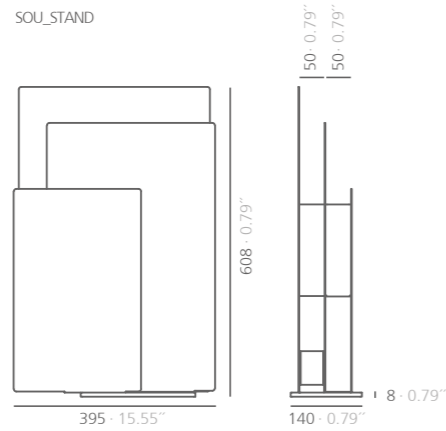

SOU_WALL

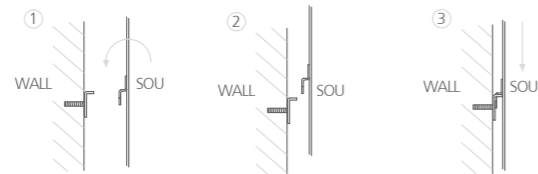
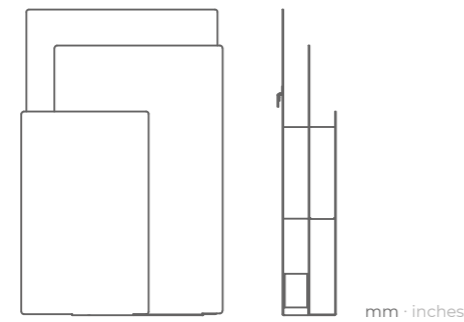

**Standing or
wall-mounted**

**There's no bad
weather when
there's good design!**

by TOMOYA TABUCHI

**Japanese designer with
extensive experience in
the design, research and
development of furniture
manufacturing. Founder
of Office for Creation.**

Diseñador japonés con
amplia experiencia en el
diseño, la investigación y el
desarrollo de la fabricación
de muebles. Fundador de
Office for Creation.



Sou by Tomoya Tabuchi

Forrein

Minimalist umbrella stand made of zinc-plated steel sheet of 2mm folded into a "U". The polyethylene base makes it dry easily.

Paragüero minimalista fabricado en plancha de acero cincado de 2mm plegada en forma de "U". Su base de polietileno permite un fácil secado.



Forrein

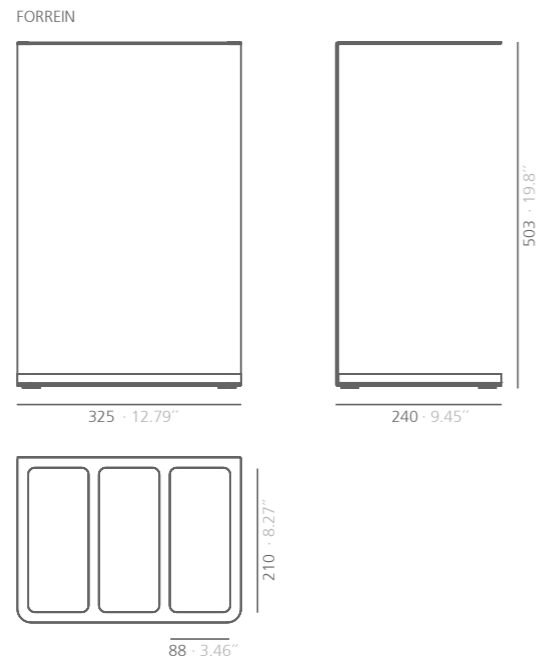

mm · inches



Easy to dry
Our favorite thing about weather? Forrein

STC Studio is part of the product design and development department of Systemtronic, integrated by a group of professionals with a wide experience in the sector.

STC Studio forma parte del departamento de diseño y desarrollo de producto de Systemtronic, compuesto por un grupo de profesionales con amplia experiencia en el sector.

by STC STUDIO

Forrein by STC Studio

Naname



Naname is the coat stand that represents the moment when the bamboo is being cut with a sword, slipping down. The textured gold Karkar finish is offered exclusively for this reference.

Naname es el perchero que representa el momento en que el bambú se corta con una espada y cae. Fabricado en acero. Se ofrece exclusivamente para esta referencia el acabado oro Karkar texturado.

Naname

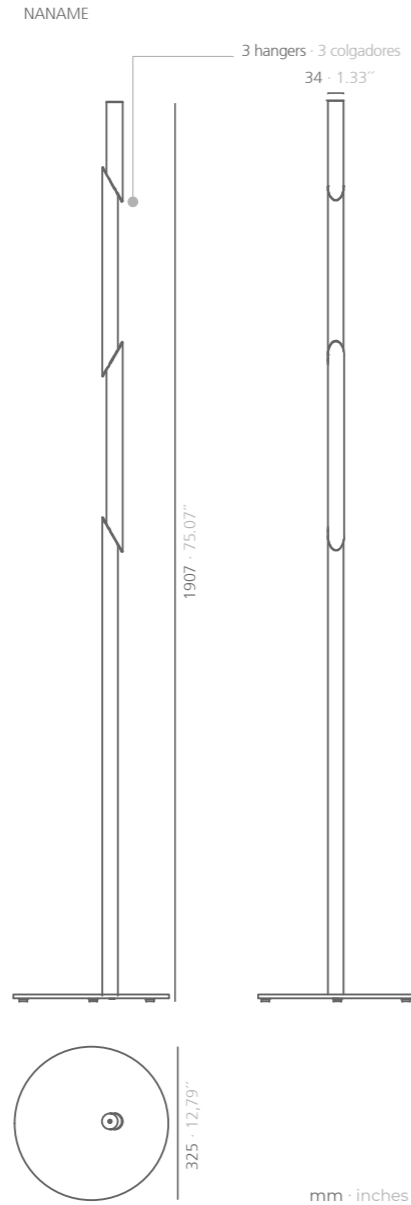

**As sculptural
as functional**

Nature-inspired

by KODAI IWAMOTO

Japanese designer who has actively collaborated with numerous furniture brands and participated in the most important fairs in the sector.

Diseñador japonés que ha colaborado activamente con numerosas marcas de mueble y participado en las más importantes ferias del sector.



Naname by Kodai Iwamoto

Second Tree

The coat stand **Second Tree** is the abstraction of the nature forms, conserving the oak-tree's soul and warmth. It stands out for its fine finish, following Systemtronic's quality philosophy, and the contrast that provides combining a noble material with steel.

El perchero **Second Tree** es la abstracción de formas de la naturaleza conservando el alma y la calidez del roble. Destaca por la calidad de su acabado y el contraste que aporta al combinar el material noble con el acero.



Second Tree by Pablo Gironés

Second Tree

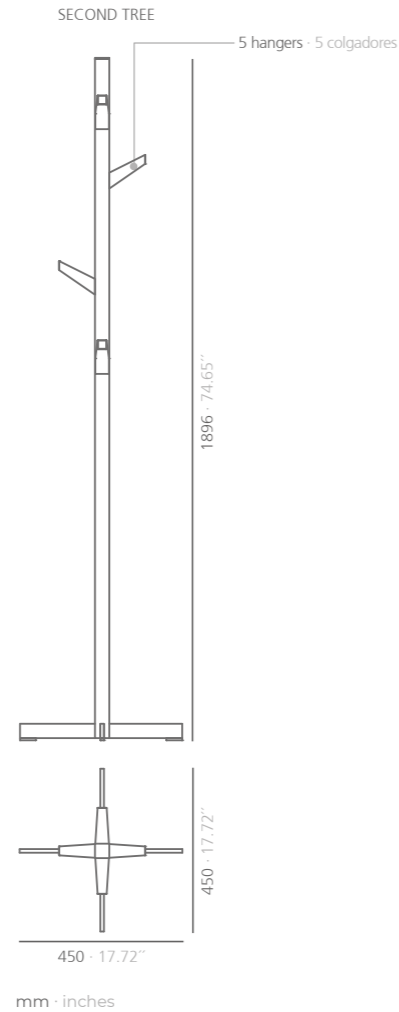

Conserving the oak-tree's soul and warmth

by PABLO GIRONÉS

Designer in charge of Marketing and Product at the company Gandía Blasco S.A. He has collaborated with companies in defining their product strategies, such as Punt Mobles and Mad Lab.

Diseñador encargado de Marketing y Producto en la compañía Gandía Blasco S.A. Ha colaborado con empresas en la definición de sus estrategias de producto, como Punt Mobles y Mad Lab.



Second Tree by Pablo Gironés

Second Tree Wall

Wall-mounted coat rack composed of natural oak wood hangers on a metal plate.

Perchero a pared compuesto por colgadores de madera natural de roble sobre una plancha metálica



Second Tree Wall

SECOND TREE WALL

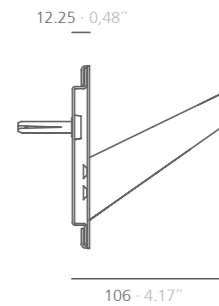
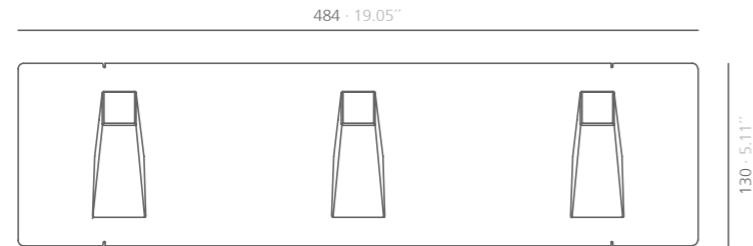

mm · inches



**an invitation to shake
off the cold**

by PABLO GIRONÉS

**Designer in charge
of Marketing and
Product at the company
Gandía Blasco S.A. He
has collaborated with
companies in defining their
product strategies, such as
Punt Mobles and Mad Lab.**

Diseñador encargado de Marketing y Producto en la compañía Gandía Blasco S.A. Ha colaborado con empresas en la definición de sus estrategias de producto, como Punt Mobles y Mad Lab.



Second Tree Wall by Pablo Gironés

Ker



Exclusive coat stand formed by beech wood bars and a steel ring painted in several colors.

Perchero exclusivo compuesto por barras de madera de haya y un aro de acero pintado en varios colores.

Ker

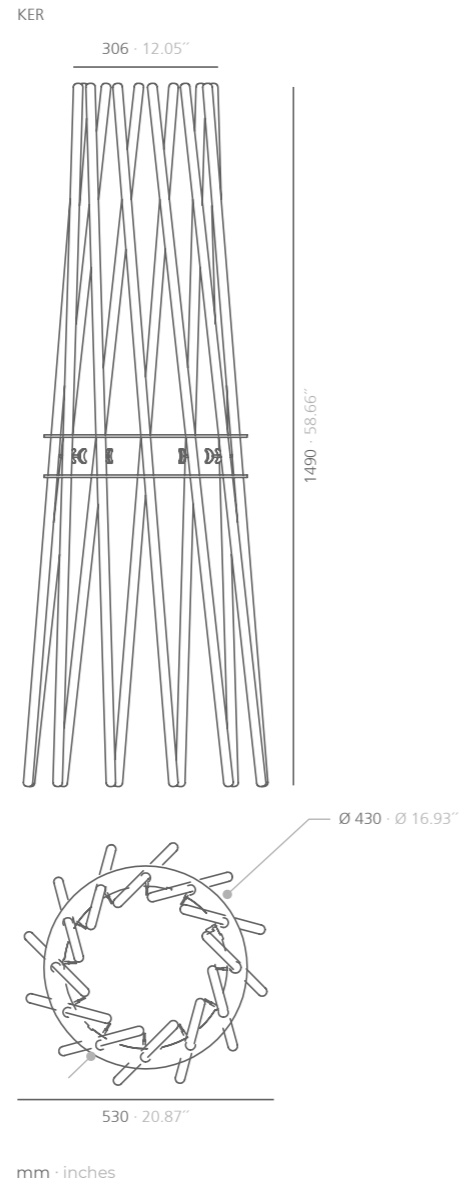

**There's no chaos
when there's Ker**

by LLUÏSA MORATÓ

**Spanish designer with a
multidisciplinary training
and a global vision when
facing each project.**

Diseñadora española
con una formación
multidisciplinar y una
visión global a la hora de
afrontar cada proyecto.



Ker by Lluïsa Morató

Elica

The best way to say welcome!

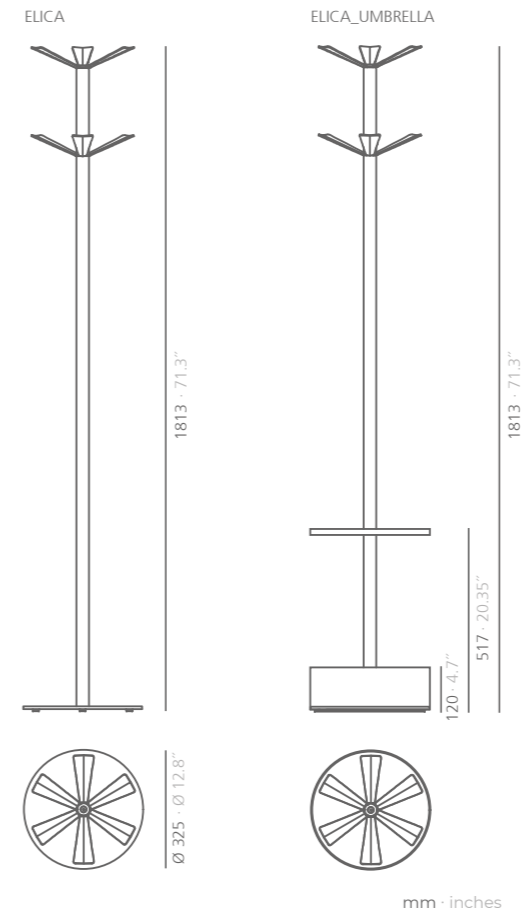

Coat racks family. One of its versions shares the function of umbrella stand. The layout and design of its propellers optimize the space.

Familia de percheros. Una de sus versiones comparte la función de paraguero. La disposición y el diseño de sus hélices optimizan el espacio.

Elica by Fernando Gil

Now comfort is portable,



take it with you

Elica Mini

Elica Mini is light and portable, allowing you to have your belongings close and in sight.

Elica Mini es ligera y portátil, lo que permite mantener tus pertenencias cerca y a la vista.



mm · inches



Branch



Coat stand with metallic hangers that evoke the branches of a tree. Available in several finishes.

Perchero con colgadores metálicos que evocan las ramas de los árboles. Disponible en varios acabados.

Branch

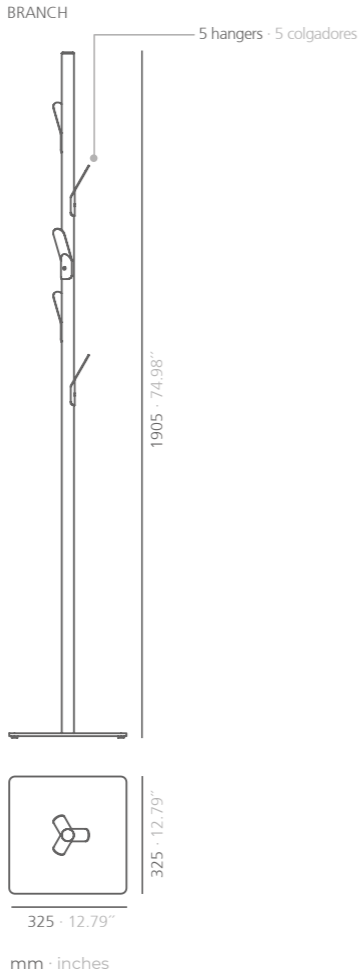

Evokes the branches of a tree

STC Studio is part of the product design and development department of Systemtronic, integrated by a group of professionals with a wide experience in the sector.

STC Studio forma parte del departamento de diseño y desarrollo de producto de Systemtronic, compuesto por un grupo de profesionales con amplia experiencia en el sector.

by STC STUDIO

Branch by STC Studio

Inlin

Keep your clothes handy!

Lightness and stability defines this piece. A coat rack formed by two columns of anodized aluminum with a matte silver finish. There are two versions: with casters or with adjustable feet. Its steel base and bottom rail may have a white, black or anthracite gray finish. The upper crossbar has a chrome finish. One of its versions allows adapting a metallic shelve adjustable in height and a cover on the base.

Ligereza y estabilidad definen a este producto, compuesto por dos columnas de aluminio anodizado con un acabado plata mate. Está disponible con ruedas o pies regulables. Su base y travesaño inferior de acero pueden tener un acabado blanco, negro o gris antracita. El travesaño superior presenta un acabado cromado. El Inlin de anchura 758mm permite adaptar un estante metálico regulable en altura y una tapa en la base.



Inlin



INL15PF
adjustable feet · pies regulables

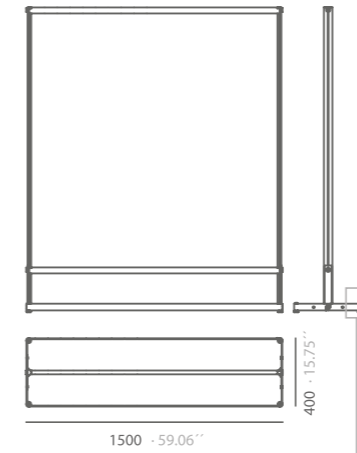

INL15RD
wheels · ruedas

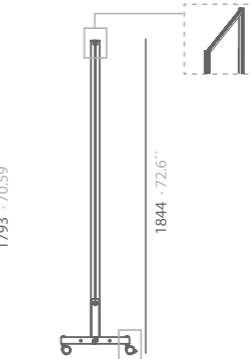

INL7PF / INL15PF
adjustable feet · pies regulables

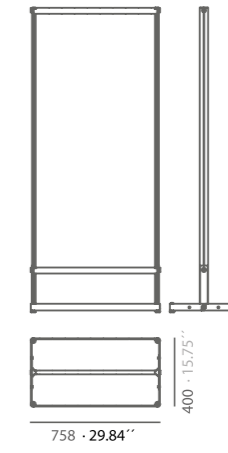

INL7RD / INL15RD
wheels · ruedas

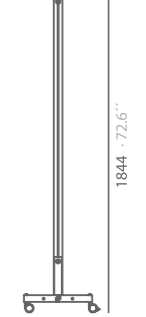

INLD15PF
adjustable feet · pies regulables

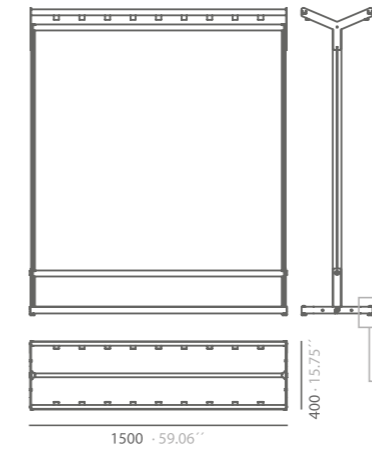

INLD15RD
wheels · ruedas

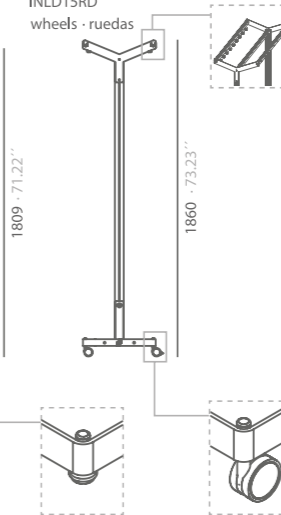

mm · inches

INLIN 758 ACCESSORIES · ACCESORIOS

INLEST
shelf adjustable in height 27.56" x 11.81"
· estante regulable en altura 700 x 300 mm

INLBAS
base cover 30.04" x 15.94"
· tapa base 763 x 405 mm

Imper

The perfect combination!

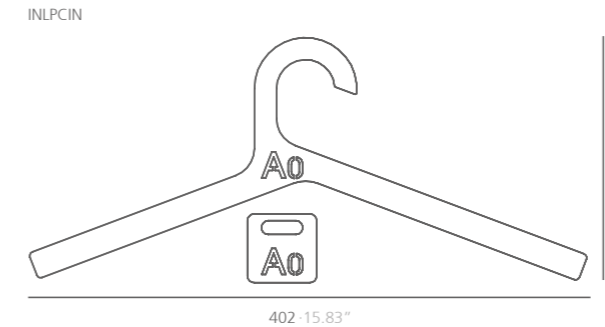
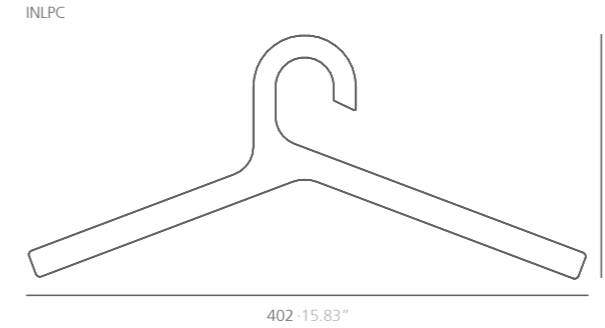
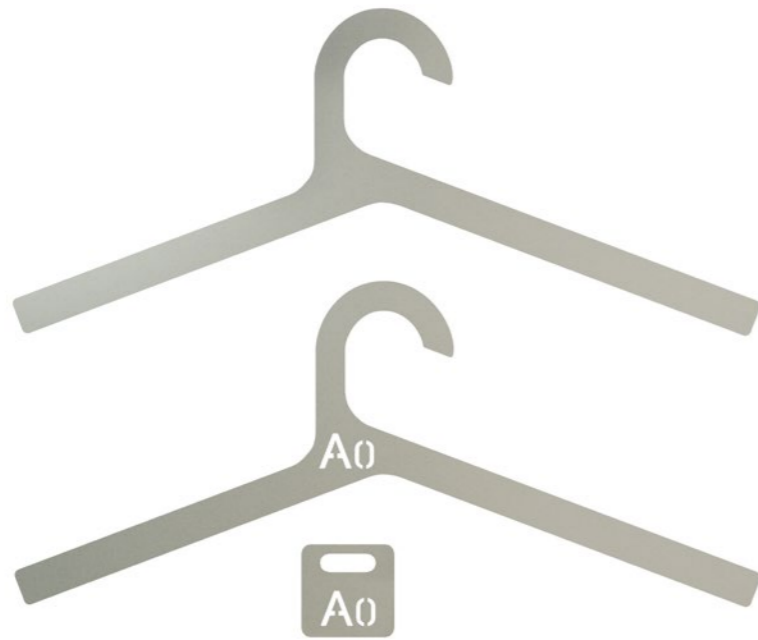

mm · inches

Stylish and lightweight hangers made in sandblasted aluminum and available with or without alphanumeric identification. These hangers complement other Systemtronic products such as: Inlin, Buraco, Pointo, Climb...

Minimum order of 10 units is required for alphanumeric identification (0-9). Code letters according to stock availability.

Elegantes y ligeras perchas de aluminio arenado disponibles con o sin identificación alfanumérica. Estas perchas complementan otros productos de Systemtronic como Inlin, Buraco, Pointo, Climb...

Para pedidos de perchas con identificación alfanumérica, la cantidad mínima es de 10 unidades (0-9). La letra varía según disponibilidad en stock.

Cantha

Wall coat racks made of aluminum. Its irregular shape, added to the slight curvature of the plate, give them a touch of elegance and originality. Available in 4 sizes and various paint finishes with or without oak face veneer.

Percheros a pared fabricados en aluminio. Su forma irregular, sumada a la ligera curvatura de la plancha, les confieren un toque de elegancia y originalidad. Disponibles en 4 tamaños y varios acabados de pintura con o sin chapado frontal de roble.

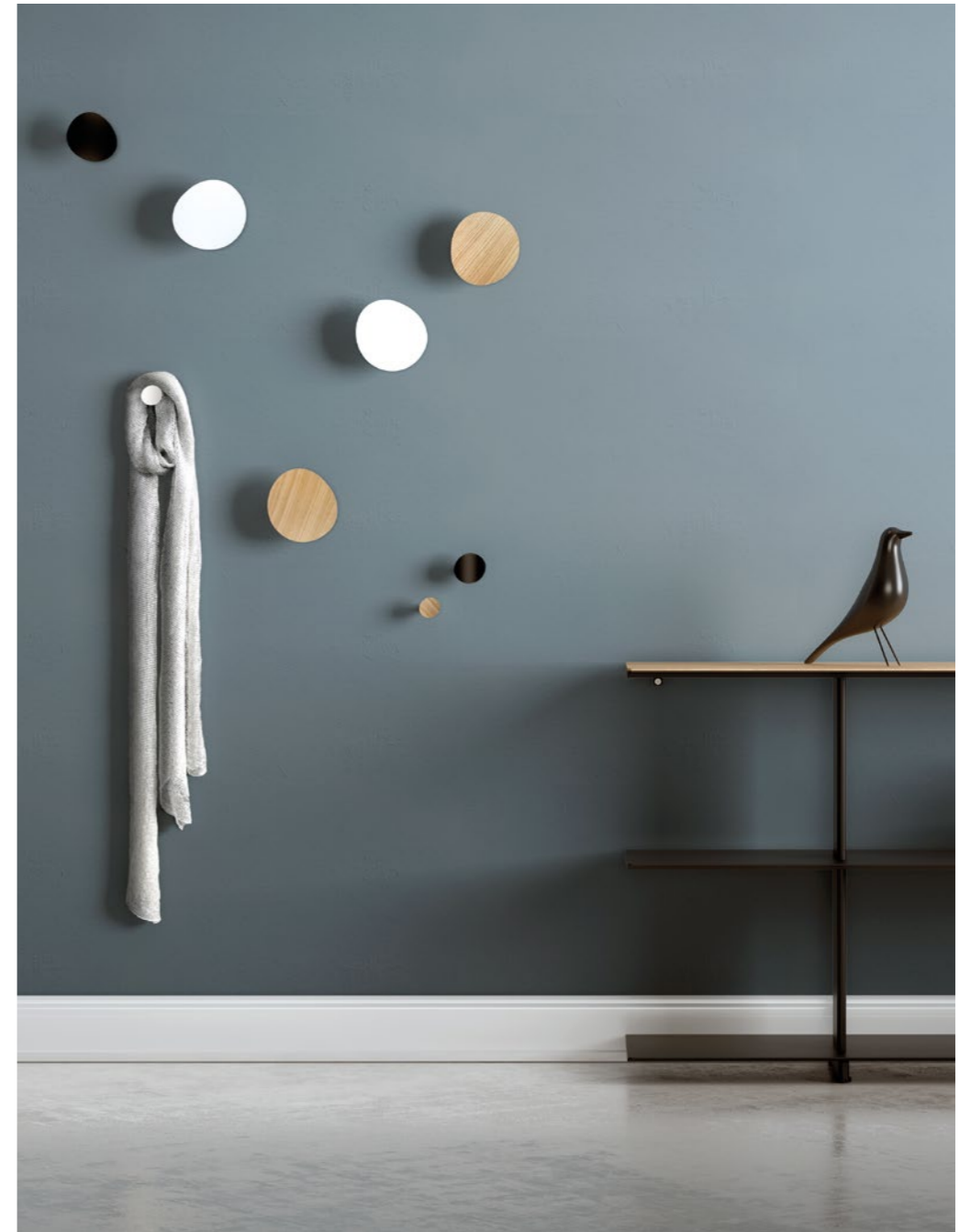

Cantha by Paula Chacártegui

Cantha

CANTHA_S

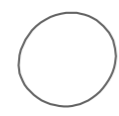
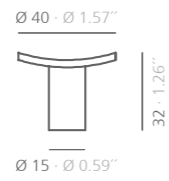

CANTHA_M

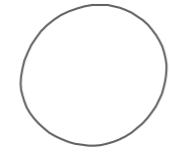
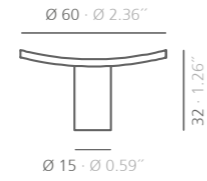

CANTHA_L

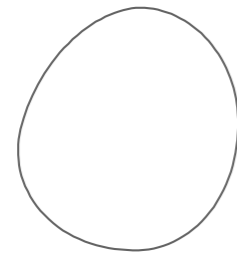
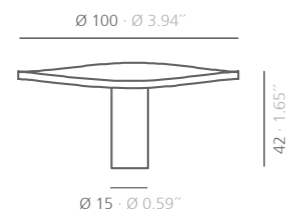

CANTHA_XL

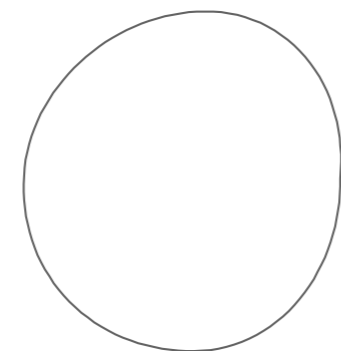
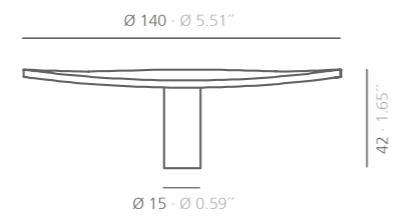

mm · inches



an invitation
to shake off the cold

by PAULA CHACÁRTEGUI

Spanish designer specialized in luxury design and crafts. She currently works in the interior design office am29, from where she develops products for the hotel sector.

Diseñadora española especializada en diseño de lujo y artesanía. Actualmente trabaja en el despacho de diseño de interiores am29, desde donde desarrolla productos para el sector hotelero.

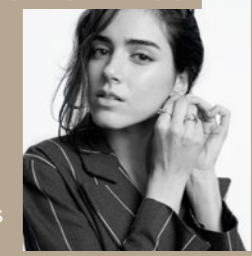

Cantha by Paula Chacártegui

Pointo

Find the things that connect with you!

Attractive hangers with a variety of colors and shapes, allowing multiple compositions on walls. Manufactured in painted steel plate, or combined with a matte oak finish front. They have a simple fixation system, either anchored to the wall or magnetic.

Atractivos colgadores que por la variedad de sus colores y formas permiten hacer múltiples composiciones en paredes. Fabricados en plancha de acero pintada, o combinado con frontal de acabado roble mate. Tienen un sencillo sistema de fijación, ya sea anclado a pared o magnético.

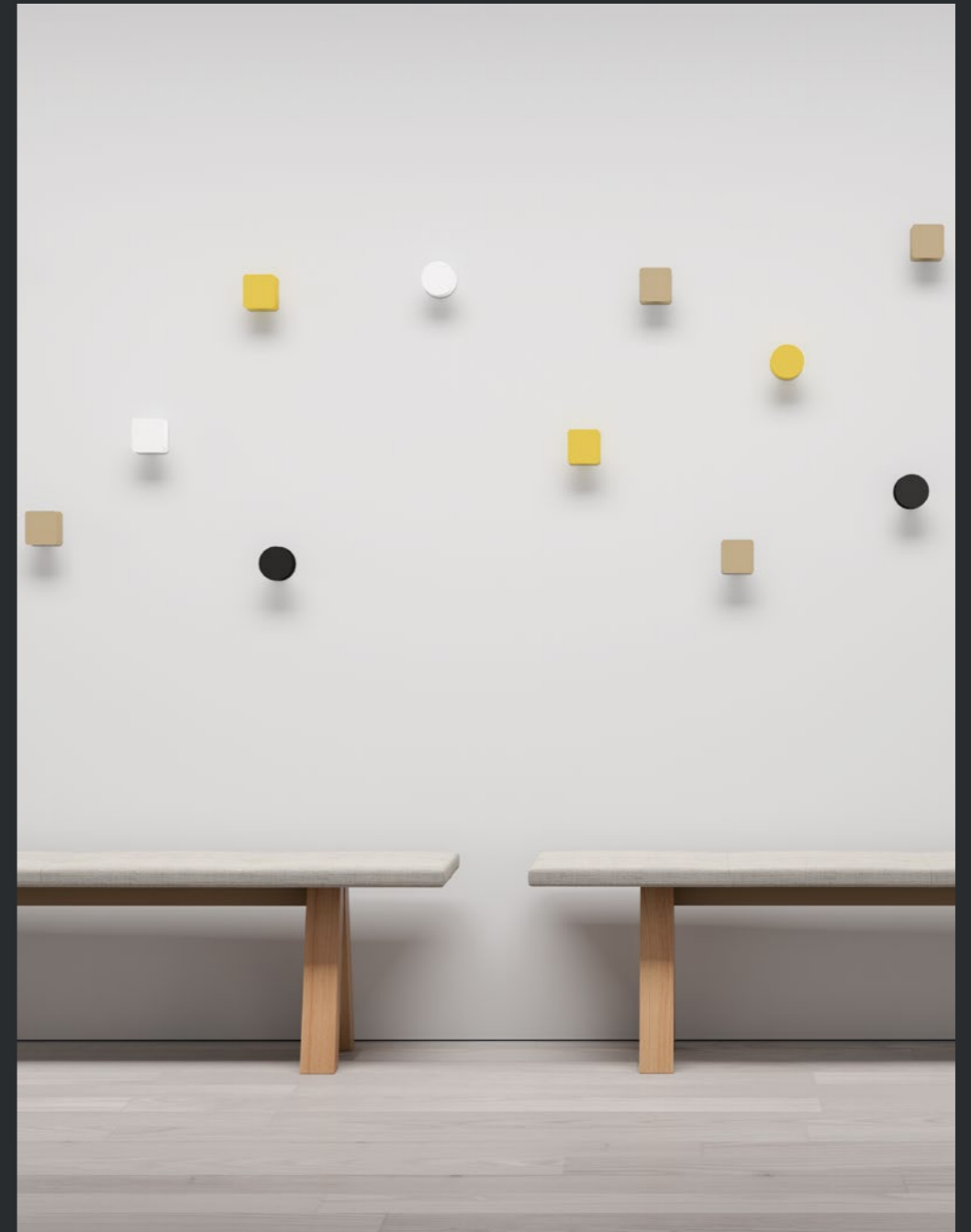

Pointo by STC Studio

Pointo

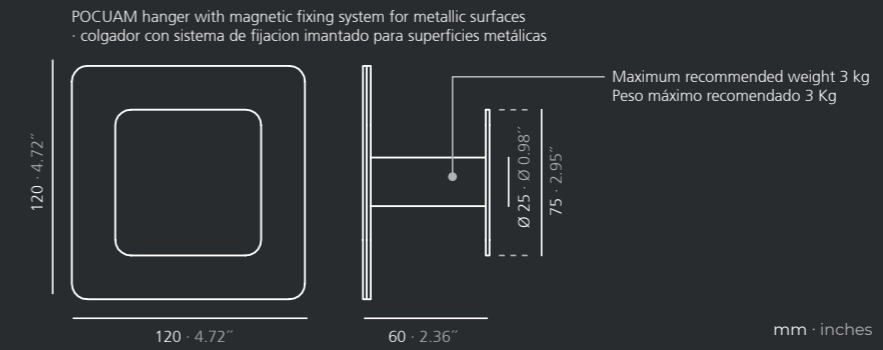
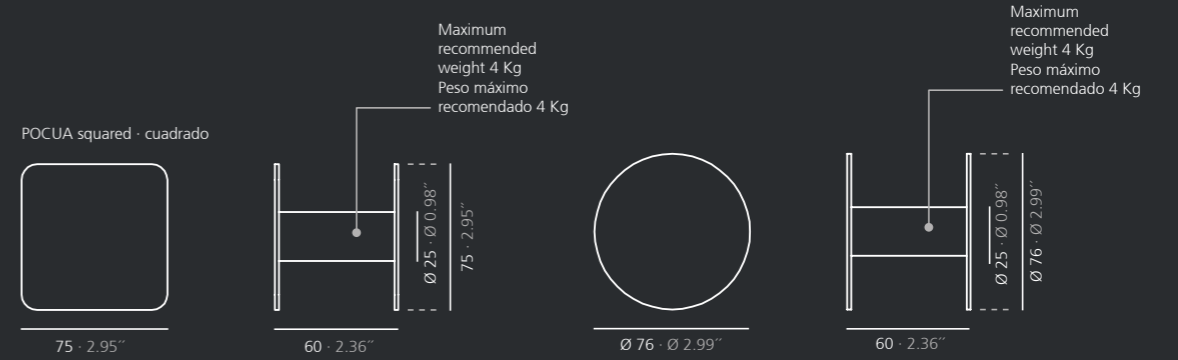
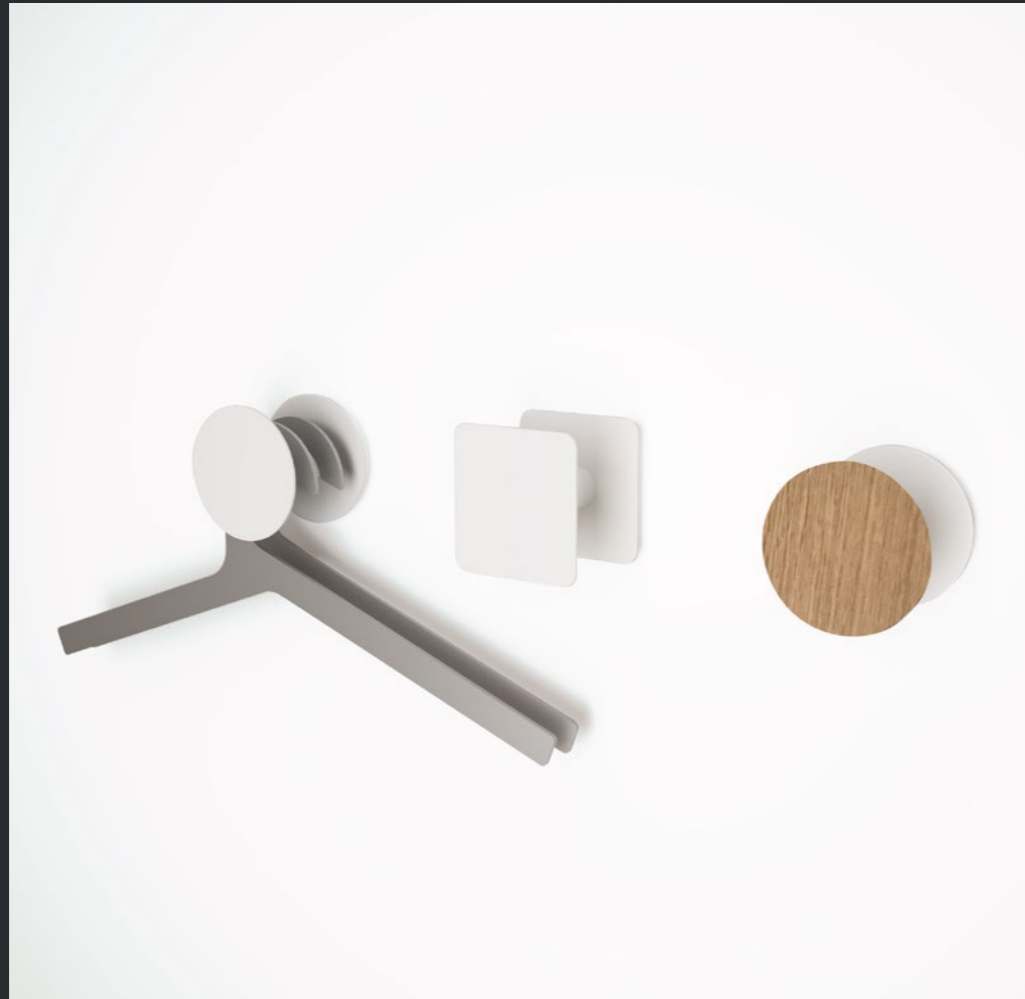

Climb

Exquisite details make interiors sing

Wall rack made of aluminum and available in six different lengths. The hanger fixing system on the profile simplifies its assembly.

Perchero de pared fabricado en aluminio y disponible en seis longitudes diferentes. El sistema de fijación de los colgadores al perfil simplifica su montaje.



Climb



CLI1 1 hanger / 1 colgador



44 · 1.73"

Maximum recommended weight 4 kg
Peso máximo recomendado 4 Kg

CLI2 2 hangers / 2 colgadores

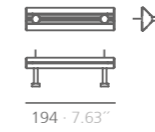

194 · 7.63"

Maximum recommended weight 10 kg
Peso máximo recomendado 10 Kg

CLI3 3 hangers / 3 colgadores

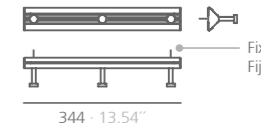

344 · 13.54"

Maximum recommended weight 10 kg
Peso máximo recomendado 10 Kg

CLI4 4 hangers / 4 colgadores

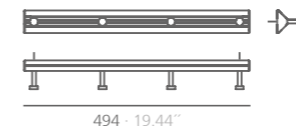

494 · 19.44"

Maximum recommended weight 10 kg
Peso máximo recomendado 10 Kg

CLI7 7 hangers / 7 colgadores

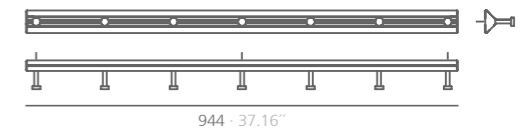

944 · 37.16"

Maximum recommended weight 15 kg
Peso máximo recomendado 15 Kg

CLI15 15 hangers / 15 colgadores

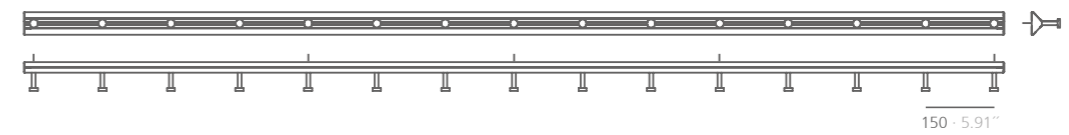

150 · 5.91"

2144 · 84.41"

Maximum recommended weight 20 kg
Peso máximo recomendado 20 Kg

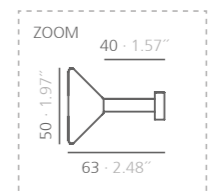

mm · inches

Buraco

Could I leave my bag and take the Buraco with me?

BURACO

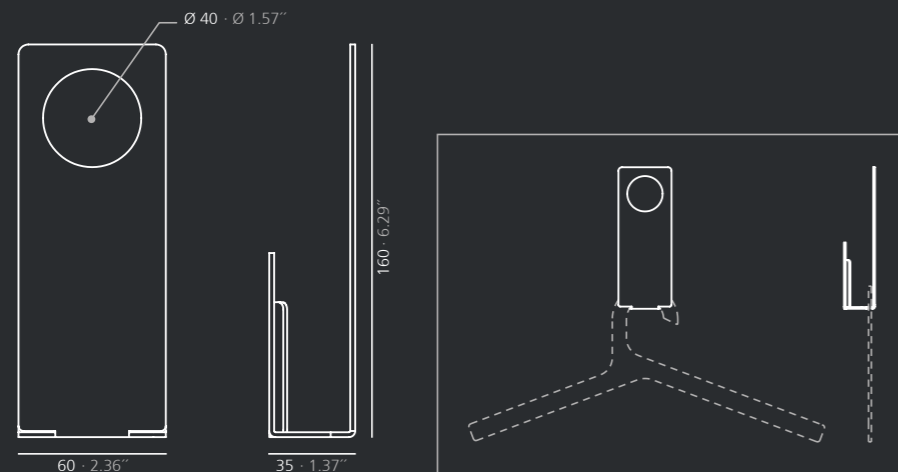

Maximum recommended weight 4 kg
It allows hanging conventional hangers

Peso máximo recomendado 4 Kg
Permite colgar perchas convencionales

mm · inches

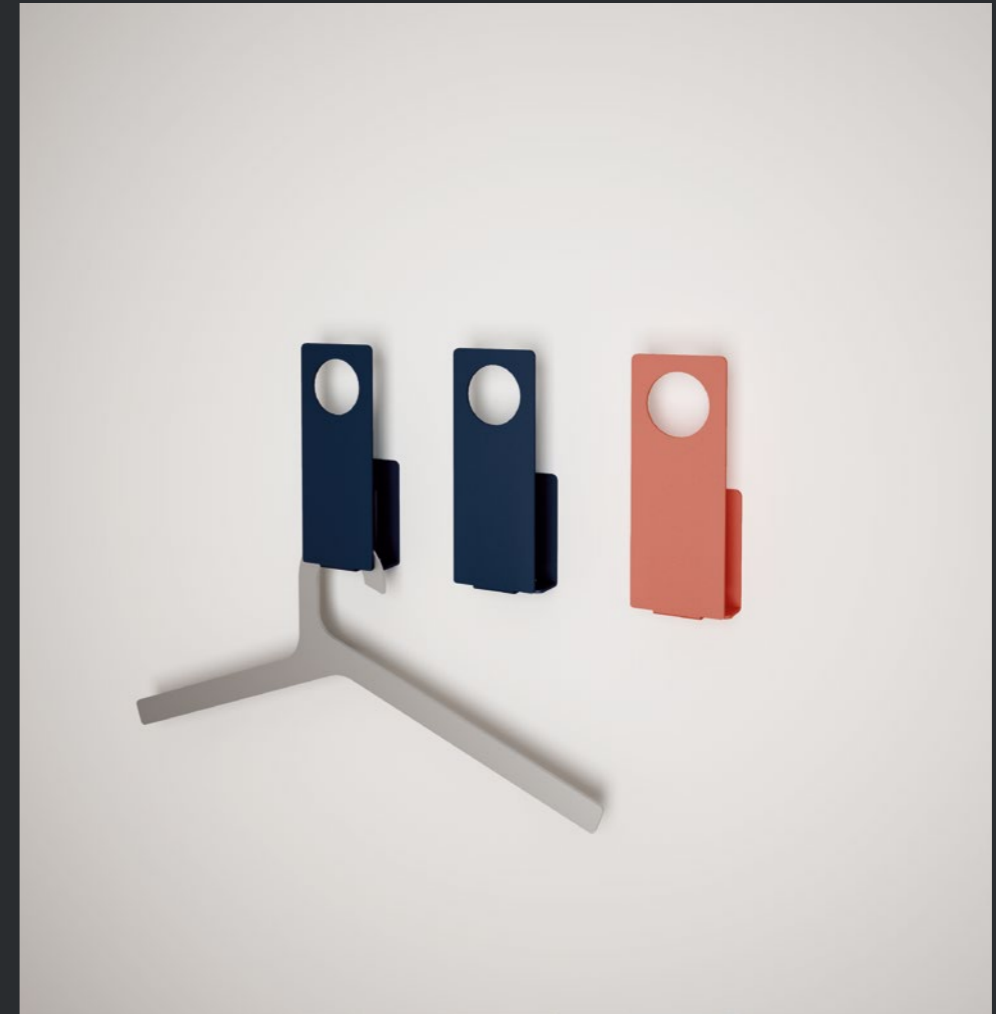

Wall hangers made of folded and painted steel sheet. Its design makes it an interesting, functional and decorative element.

Colgadores de pared fabricados en plancha de acero plegada y pintada. Su diseño los convierte en un interesante elemento a nivel funcional y decorativo.

Buraco by Aranda Aloy Enblanc

SITA

Screen in the Air (SITA) is a versatile support for televisions and monitors, suitable for homes, common areas and meeting rooms. It stands out for its elegant back which hides electrical connections providing an impeccable image.

Mounting interface standard VESA 75, 100, 200, 300 and 400, with possibility of VESA accessory for 600 and 800. The monitor can rotate 240°. Its casters allows its movement.
Maximum size: 75".
Maximum weight: 40kg.
SITABO box container available.
Produced in steel.

Screen In the Air (SITA) es un soporte para televisiones y monitores versátil e idóneo para hogares, zonas comunes y salas de reuniones. Destaca por su elegante trasera que oculta las conexiones eléctricas proporcionando una imagen cuidada.

Interface de montaje standar VESA 75, 100, 200, 300 y 400 con posibilidad de accesorio VESA para 600 y 800. El monitor se puede girar 240°. Dispone de ruedas para poder moverlo.
Tamaño máximo: 75".
Peso máximo: 40kg.
Disponible cajón contenedor SITABO.
Fabricado en acero.





Sita

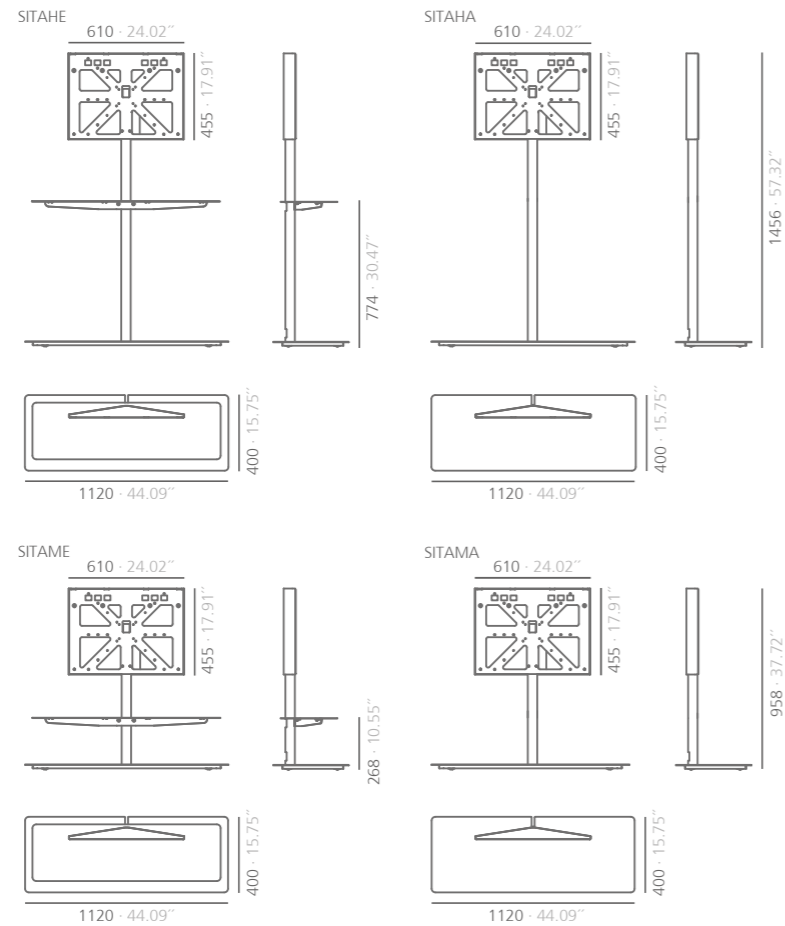

mm · inches



Screen
in the air

Multiple
rotations

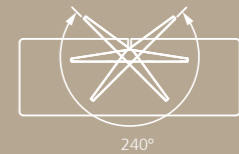

Movement · Desplazamiento



Its design includes 4 small casters which facilitate forward and backward movement.
El diseño incluye 4 pequeñas ruedas que facilitan su desplazamiento hacia delante y hacia atrás.



Rotary movement of the set can be obtained equipping the optional wheel kit.
Para un movimiento rotatorio del SITA se ofertan otro tipo de ruedas.

Sitave

accessorie for VESA 600 or 800
accesorio para VESA 600 ó 800

STC Studio is part of the product design and development department of Systemtronic, integrated by a group of professionals with a wide experience in the sector.

STC Studio forma parte del departamento de diseño y desarrollo de producto de Systemtronic, compuesto por un grupo de profesionales con amplia experiencia en el sector.

by **STC STUDIO**

Sitabo

An elegant solution for your multimedia equipment!

Elegant module container for the multimedia equipment. The design contains a fixed magnetic back cover which gives an easy access. The furniture disposes of two openings: one at the base for the cable guide, and another at the cover for the ventilation of the equipment.

Elegante módulo contenedor para incluir los equipos multimedia. El diseño contiene una tapa trasera de fijación magnética que facilita el acceso. El mueble dispone de dos aberturas, una en la base para el guiado de los cables y otra en la tapa para procurar la ventilación de los equipos.



SITABO

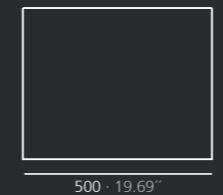

400 · 15.75\"/>

It includes 4 small casters.
Incluye 4 ruedas pequeñas.

Movement: Desplazamiento



Its design includes 4 small casters which facilitate forward and backward movement.
El diseño incluye 4 pequeñas ruedas que facilitan su desplazamiento hacia delante y hacia atrás.

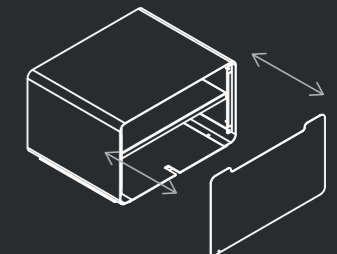
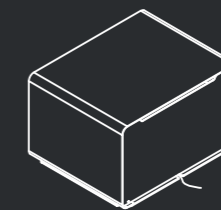
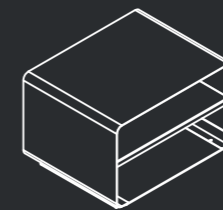

mm · inches

your reception

systemtronic

Meet our family

- 1-Crepe plant pot
Finish: Textured silk grey RAL 7044.
- 2-Conee pouf
Finish: White.
- 3-Naname
Finish: Textured blue RAL 5011.
- 4-Faya
Finish: Textured blue RAL 5011.
- 5-Celes
Finish: Textured blue RAL 5011.
- 6-Green Light wall
Finish: Textured silk grey RAL 7044.



Without a doubt, the reception and the furniture that coexist in it are the first image of the entity to which they belong, hence the importance of taking care of its design. Systemtronic has numerous products to solve the requirements of this type of space. With an aesthetic marked by elegance, simplicity and multifunctionality, many of our solutions are part of product families, which is suitable to give unity to the interior design.

Sin lugar a dudas, la recepción y los muebles que en ella coexisten es el primer impacto de imagen de la entidad a la que pertenecen, de ahí la importancia de cuidar su diseño. Systemtronic cuenta con numerosos productos para dar solución a los requerimientos de este tipo de espacio. Con una estética marcada por la elegancia, la sencillez y la multifuncionalidad, muchos de ellos incluso forman parte de familias de productos, lo que es conveniente a la hora de darle unidad a la propuesta.

your reception
systemtronic

Meet our family



Your time, your schedule,



your style!

Nube

Irregular circular shaped clock with 45mm of thickness. Produced in lacquered MDF in different colors, or solid oak. Available in two sizes.

Reloj de pared de forma circular irregular de 45mm de espesor. Fabricado en MDF lacado en diferentes colores o en roble macizo. Disponible en dos tamaños.

Nube34

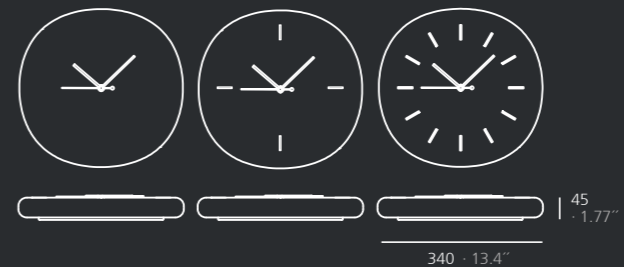

Nube48

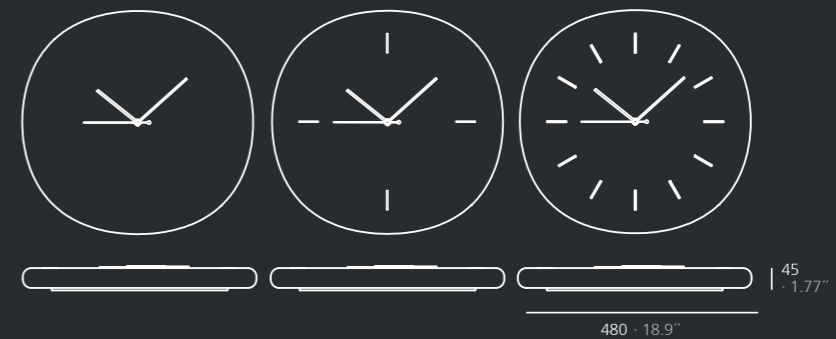

mm · inches

Nube by Víctor Carrasco

Baldas

**Creativity has
no limits; this
product either**

Modular shelves of linear aesthetics in vertical and horizontal disposition, that allow multiple compositions to suit the needs of each space. Produced in aluminum.

Baldas modulares de estética lineal en disposición vertical y horizontal, que permiten múltiples composiciones para adaptarse a las necesidades de cada espacio. Fabricadas en aluminio.



Baldas by Víctor Carrasco

Baldas



Modular
Elegant
Many combinations
Strong support

BOOKSHELVES

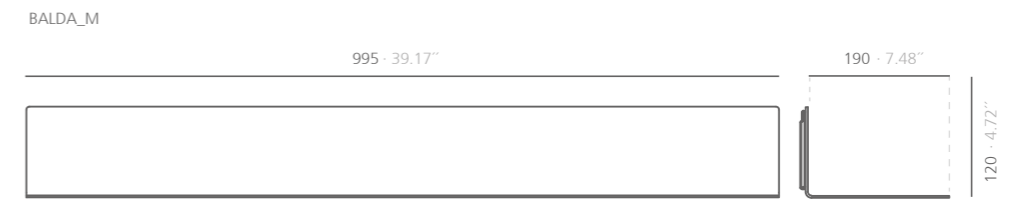
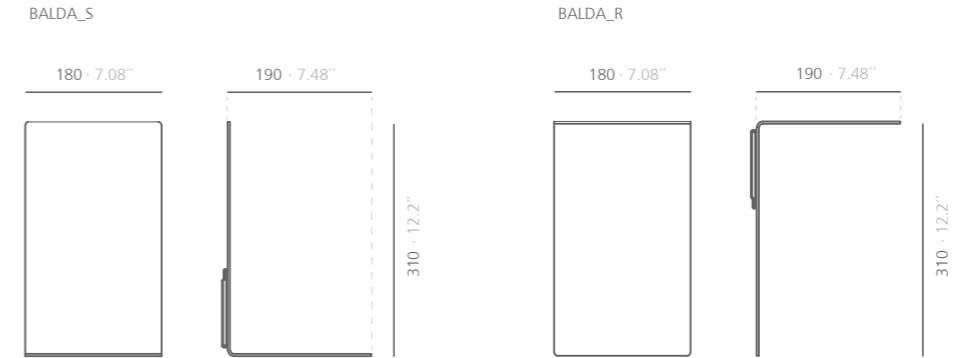

mm · inches

by VÍCTOR CARRASCO

Víctor Carrasco, strategic director of Viccarbe, has developed and positioned international brands with remarkable added value, thanks to his passion for synthesis and sustainable growth.

Víctor Carrasco, director estratégico de Viccarbe, desarrolla y posiciona marcas internacionales con un sorprendente added value gracias a su fijación por la síntesis y los crecimientos sostenibles.



Baldas by Víctor Carrasco

Usio



Usio shelving collection stands out for its clean and elegant line in all versions, perfect for small spaces. Bookcase formed by an aluminum column with an anodized silver matt finish and painted steel shelves.

La colección de estanterías Usio destaca por su línea limpia y elegante en todas sus versiones, perfecta para espacios reducidos. Librería con columna de aluminio, anodizado plata mate y estantes de acero pintados.

Usio

USP

USP single wall hanged
· sencilla a pared

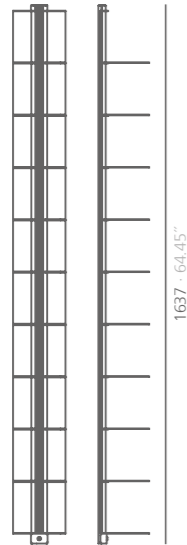

1637 · 64.45"



155 · 6.1"

USB

USB single with base
· sencilla con base

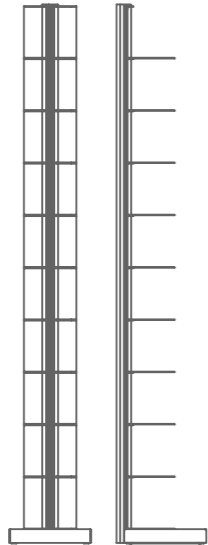

1639 · 64.53"

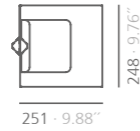

251 · 9.88"

UDB

UDB double with base
· doble con base

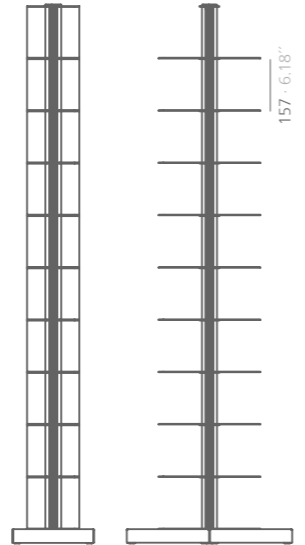

157 · 6.18"

1639 · 64.53"

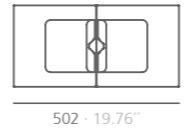

502 · 19.76"

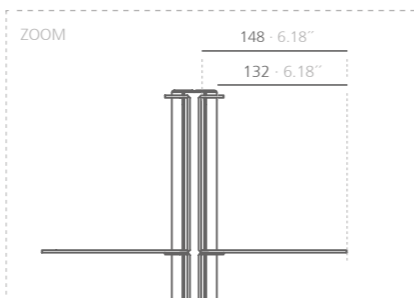

ZOOM

148 · 6.18"

132 · 6.18"

mm · inches



Book tower

Put columns to
your wisdom

STC Studio is part of the product design and development department of Systemtronic, integrated by a group of professionals with a wide experience in the sector.

STC Studio forma parte del departamento de diseño y desarrollo de producto de Systemtronic, compuesto por un grupo de profesionales con amplia experiencia en el sector.

by STC STUDIO

Usio by STC Studio

Koku

Love your books!

KOKU

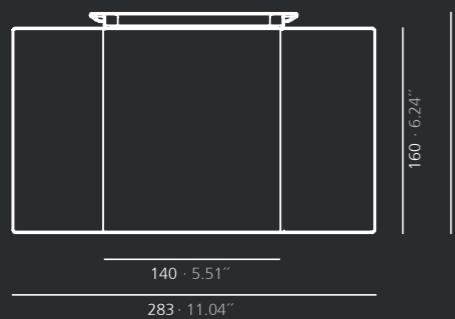

mm · inches



Singular shelves designed for your books or magazines, to cover space and functionality requirements. Manufactured in painted steel sheet with a simple wall-mounted system.

Estantes originales para tus libros o revistas, concebidos para cubrir necesidades de espacio y funcionalidad. Fabricado en plancha de acero pintado, con un sencillo sistema de fijación a pared.

Koku By Hugo Tejada

Mott

Elegance and simplicity go hand in hand

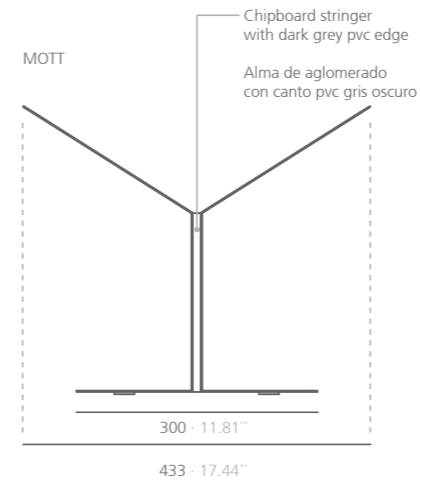

mm · inches

Magazine rack inspired by architectonic shapes. Made of steel sheet and coated with oven thermoset powder paint.

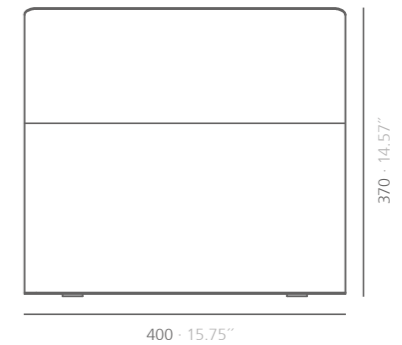

Revistero inspirado en formas arquitectónicas. Fabricado en plancha de acero y recubierto con pintura en polvo termoendurecida al horno.

Zin

Is it a magazine rack? Is it a side table? It is both!



ZIN

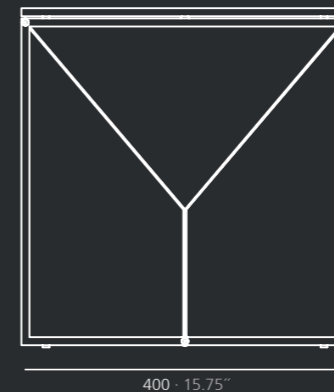

mm · inches



403 · 15.87" Without glass top
Sin tapa de cristal
415 · 16.34" With glass top
Con tapa de cristal

Singular magazine rack. Its structure allows to be use as a side table, by adapting a transparent glass top. Made of light gray screen fabric, and chromed or painted steel structure.

Singular revistero. Su estructura permite el uso como mesa auxiliar al incorporar un sobre de cristal transparente. Fabricado con tejido de screen gris claro y estructura de acero cromada o pintada.

Zin By Fernando Gil

Faya



**Discreet fire extinguisher support
made of painted steel sheet. Its casters
allow its easy movement.**

Discreto soporte para extintores
fabricado en plancha de acero pintada.
Sus ruedas permiten un cómodo
desplazamiento.

Faya

FAYA

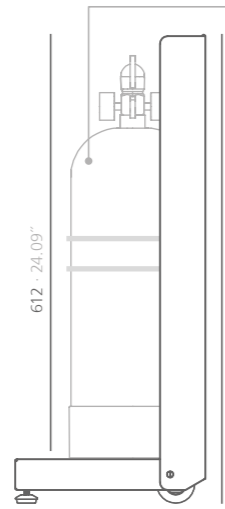
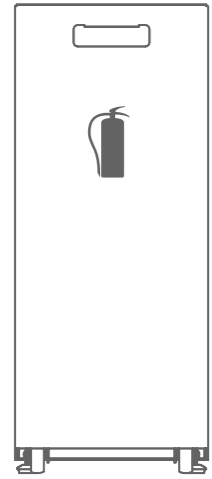

For 5 and 9 Kg extinguishers
Para extintores de 5 y 9 Kg

For special measures or any other
modification, request
Para medidas especiales o cualquier
otra modificación, consultar

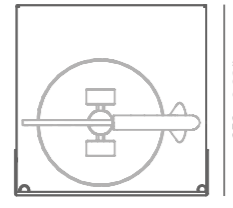

255 · 10.04\"/>

mm · inches

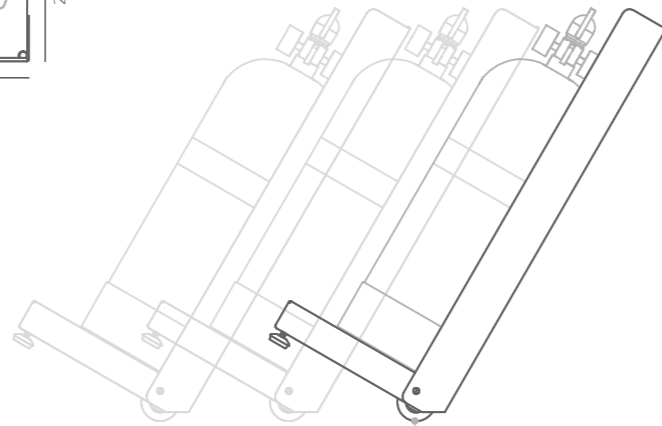

Soft rubber casters
Ruedas blandas de goma



**Keep your interior
design safe without
breaking fire regulations**

**STC Studio is part of
the product design and
development department
of Systemtronic,
integrated by a group of
professionals with a wide
experience in the sector.**

STC Studio forma parte del
departamento de diseño y
desarrollo de producto de
Systemtronic, compuesto
por un grupo de
profesionales con amplia
experiencia en el sector.

by STC STUDIO

Fum

You think you know what Minimalism is?

Ashtray column made of painted aluminum. A sealed tank that reduces smoke and smells is included. Two formats: on the wall or standing, being able to screw it to the ground. A standing version with double capacity is offered.

Columna cenicero de aluminio pintado que incluye un depósito sellado para reducir el humo y los malos olores. Dos formatos: a pared o de pie, pudiéndose atornillar a suelo. Se ofrece una versión de pie con el doble de capacidad.

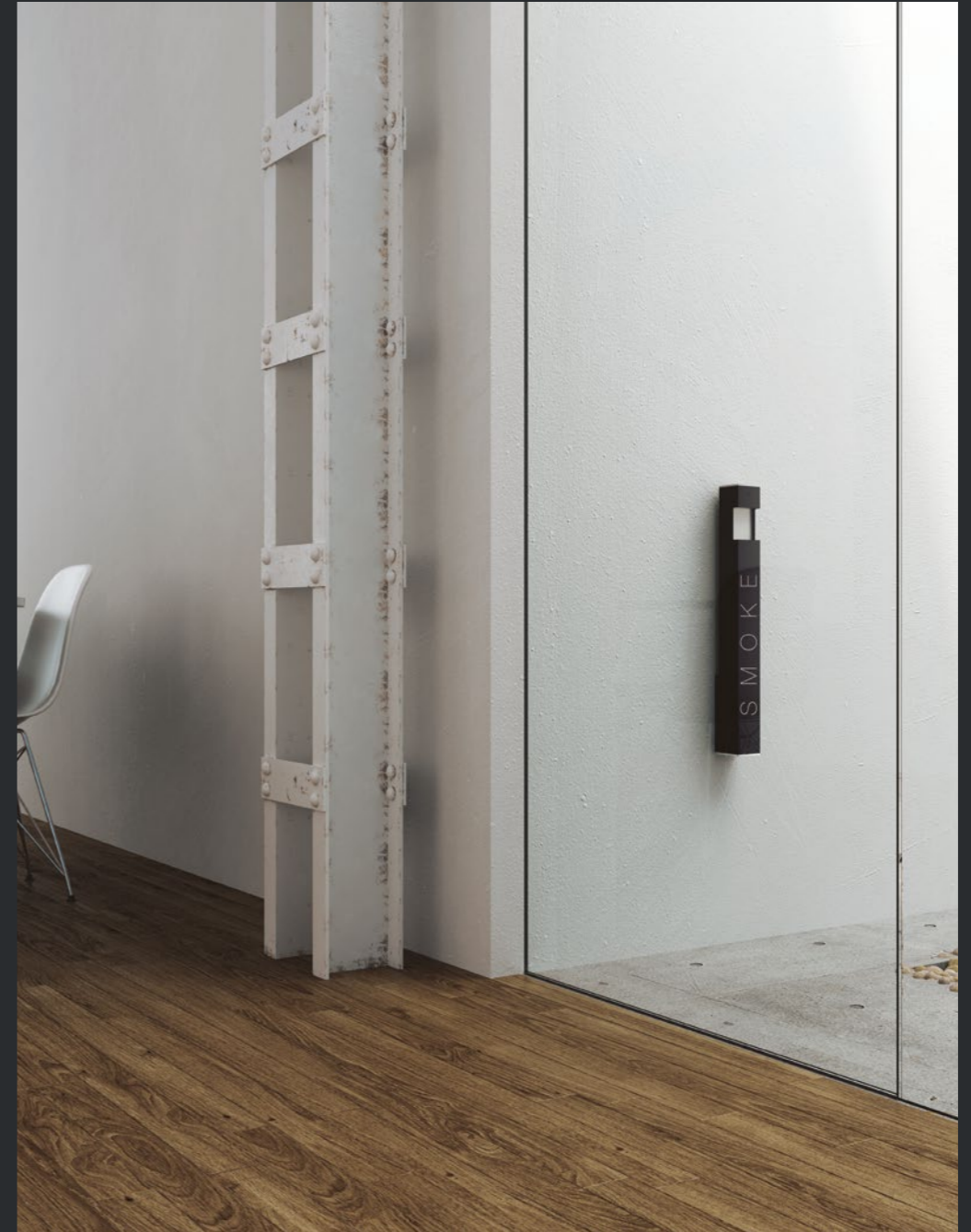

Fum



FUMPI
Self standing ashtray column
Capacity: 0.7 liters

Columna cenicero de pie
Capacidad: 0.7 litros

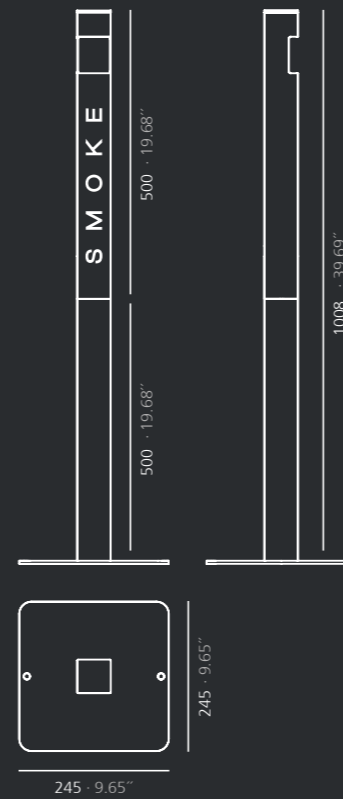

mm · inches

FUMPI2
Self standing ashtray column
Capacity: 1.4 liters

Columna cenicero de pie
Capacidad: 1.4 litros

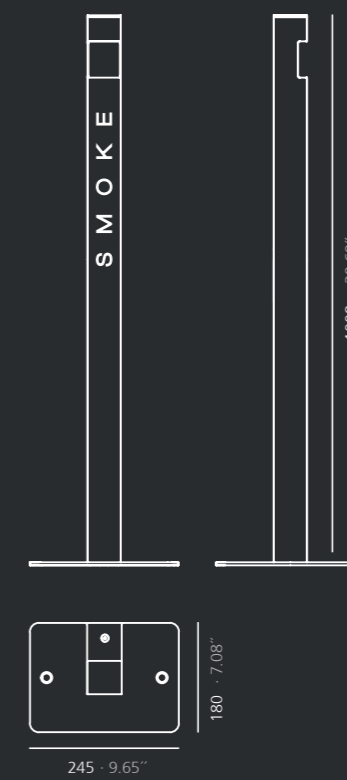

FUMPA
Wall hanged ashtray column
Capacity: 0.7 liters

Columna cenicero a pared
Capacidad: 0.7 litros



Fum By STC Studio

Trec

Set limits to everything but your goals

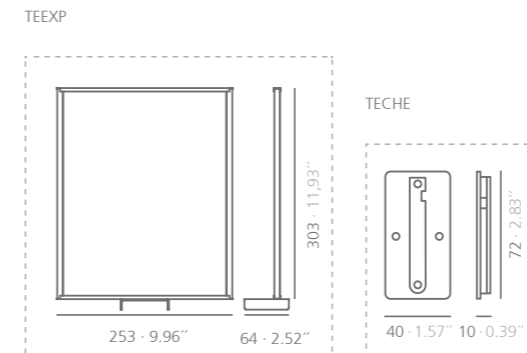
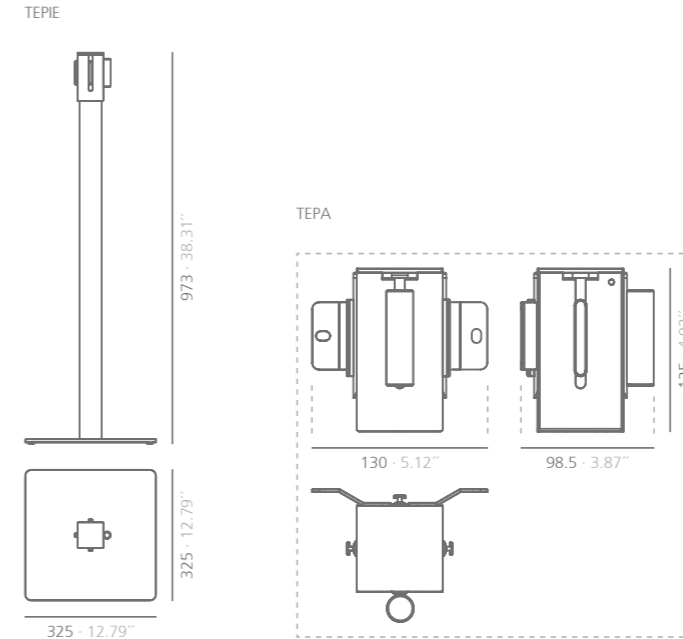

mm · inches

Collection of posts for delimiting public spaces.
Squared aluminum column and painted steel base.
3m (9.84 feet) tape available in blue, red or black.

Colección de postes para delimitar espacios públicos.
Columna cuadrada de aluminio y base de acero pintado.
Carrete de 3m disponible en azul, rojo o negro.

Lit

Two functions, one product!

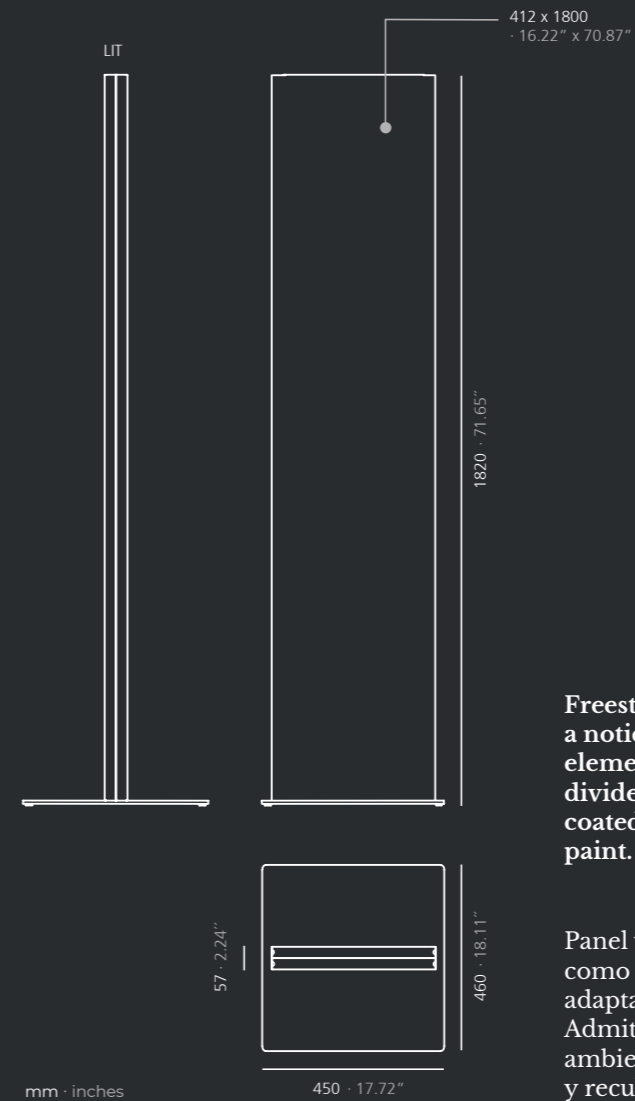

Freestanding vertical panel used as a notice panel by adapting magnetic elements. It also supports the room divider function. Made of steel and coated with oven thermoset powder paint.

Panel vertical autoportante usado como panel informativo mediante la adaptación de elementos magnéticos. Admite la función de separador de ambientes. Está fabricado en acero y recubierto con pintura en polvo termoendurecida al horno.

Lit By Pablo Gironés

Flap

Display your ideas

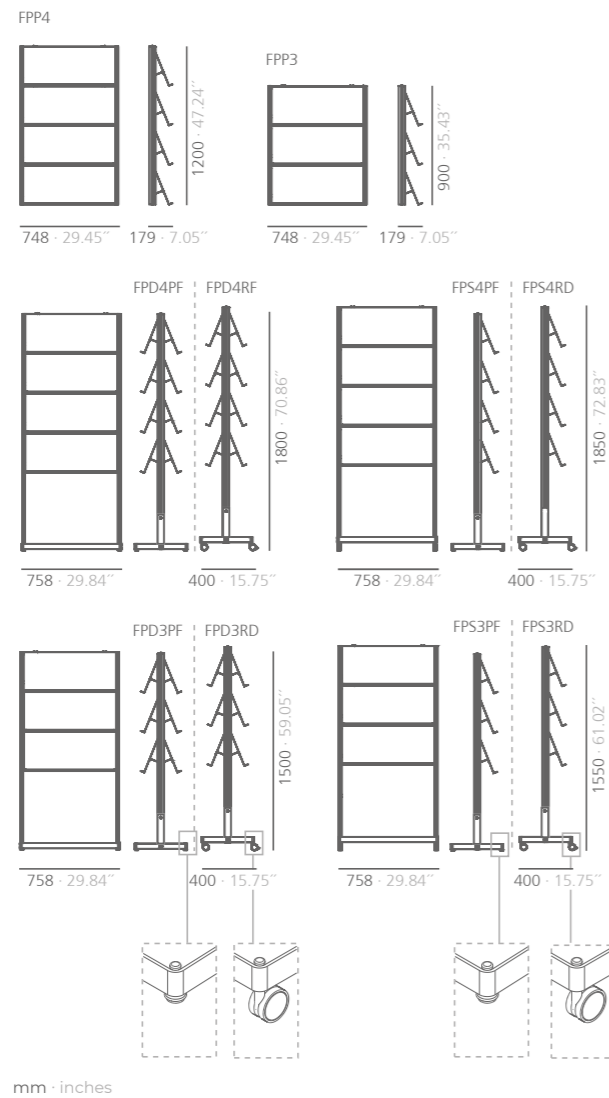

EXHIBITORS



Vertical display for magazines, newspapers, catalogues, brochures... It presents the options wall-mounted or freestanding, with adjustable feet or casters. Shelves may be on one side or both. Aluminum structure with anodized silver finish. Steel shelves and base, both coated with oven thermoset powder paint. Capacity per shelf: A4 (x3).

Expositor vertical para revistas, periódicos, catálogos, folletos publicitarios... Presenta las opciones a pared y autoportante con pies niveladores o ruedas y estantes a una cara o a ambas. Estructura de aluminio anodizado plata mate. Estantes y base de acero con revestimiento de pintura en polvo termoendurecida al horno. Capacidad por estante: A4 (x3).

Modulor

Keep everyone up to date



MODULOR_S



MODULOR_M

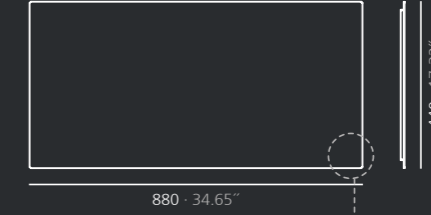

MODULOR_L

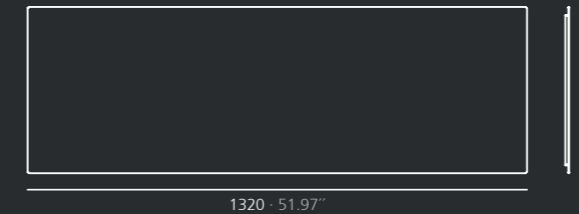

A special white finish version allows writing with dry erase markers

Un acabado especial blanco permite escritura con rotuladores de borrado en seco

mm · inches

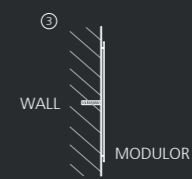
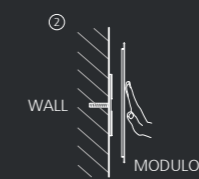
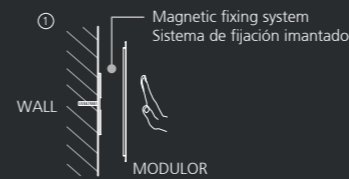

Metallic notice panels of different sizes and colors that allow adapting magnetic elements and create singular wall compositions in many spaces: informative points, offices, receptions, children's rooms, etc. A special white finish version that allows writing with dry erase markers, is offered.

Paneles informativos metálicos de diversas dimensiones y colores que permiten adaptar elementos magnéticos y crear originales composiciones de pared en múltiples espacios: puntos informativos, oficinas, recepciones, habitaciones infantiles, etc. Disponible un acabado especial blanco que permite escritura con rotuladores de borrado en seco.

Iflag

We broke the law of gravity

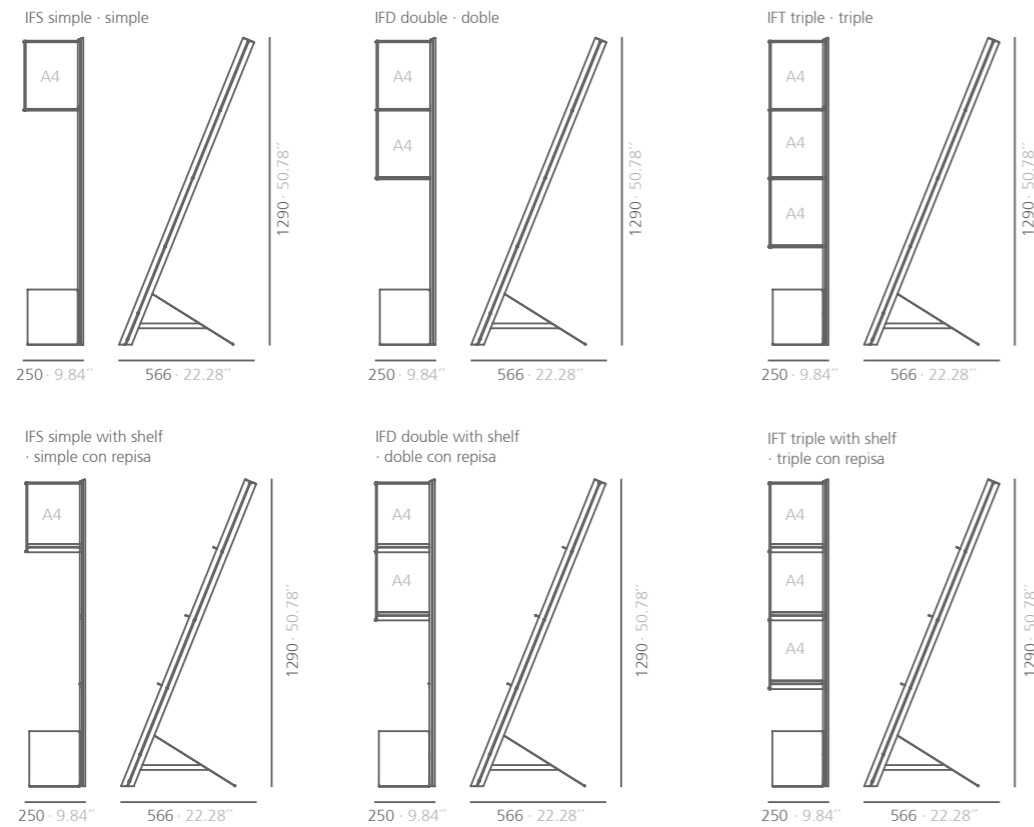

mm · inches



Transparent methacrylate display (A4 format). Versions: single, double or triple, with or without shelves. Aluminum column with anodized silver finish and steel base coated with oven thermoset powder paint.

Expositor de metacrilato transparente (formato A4). Versiones: simple, doble o triple, con o sin repisas. Columna de aluminio anodizado plata mate y base de acero recubierta con pintura en polvo termoendurecida al horno.

Atria

**What you see
is what it is:**



**light, elegant,
timeless**

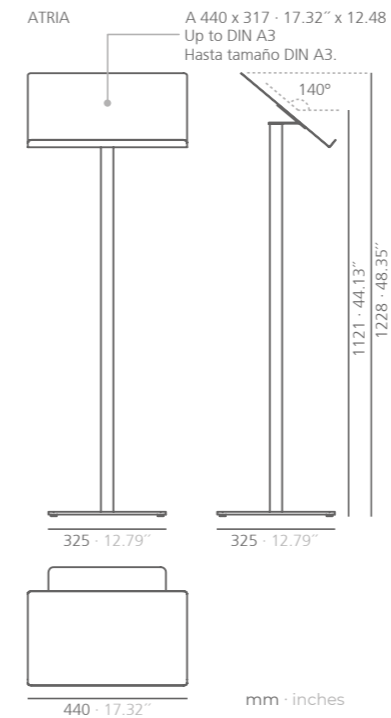

Light structure lectern. It has an aluminum column and a painted steel base and tray.

Atril de ligera estructura. Combina materiales como el aluminio de la columna y el acero pintado de su base y bandeja.

your office
systemtronic

We have your solution

- 1-Foork
Finish: White soft with matte white RAL 9003 legs and feet.
- 2-Elica
Finish: Textured forged grey.
- 3-Supp
Finish: Matte white RAL 9003.
- 4-Support
Finish: Matte white RAL 9003.
- 5-Swire
Finish: Matte white RAL 9003.
- 6-Wire
Finish: Matte white RAL 9003.
- 7-Omega
Finish: Matte white RAL 9003.
- 8-CPU
Finish: Matte white RAL 9003.
- 9-Baldas
Finish: Textured forged grey.
- 10-Store + magazine rack
Finish: Textured forged grey and mustard gloss RAL 1012.
- 11-Drop Top Triple
Finish: Textured black RAL 9011.
- 12-Parban
Finish: Textured forged grey.

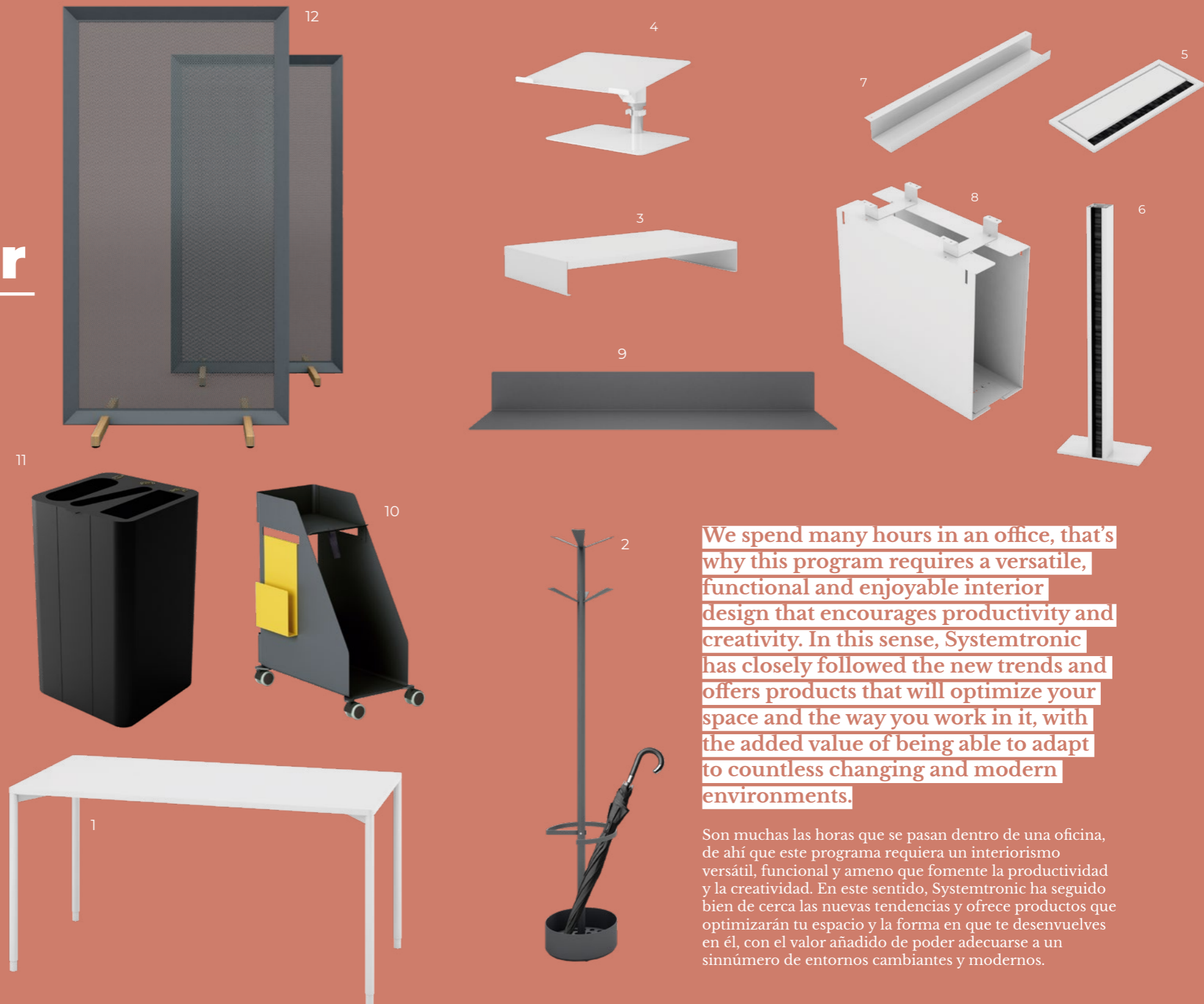

We spend many hours in an office, that's why this program requires a versatile, functional and enjoyable interior design that encourages productivity and creativity. In this sense, Systemtronic has closely followed the new trends and offers products that will optimize your space and the way you work in it, with the added value of being able to adapt to countless changing and modern environments.

Son muchas las horas que se pasan dentro de una oficina, de ahí que este programa requiera un interiorismo versátil, funcional y ameno que fomente la productividad y la creatividad. En este sentido, Systemtronic ha seguido bien de cerca las nuevas tendencias y ofrece productos que optimizarán tu espacio y la forma en que te desenvuelves en él, con el valor añadido de poder adecuarse a un sinnúmero de entornos cambiantes y modernos.

your office
systemtronic

We
have your
solution



Fork



The design of these tables is characterized by being able to combine the colors of their legs with their regulating feet made of solid painted aluminum. Fork tables are designed to be combined with each other and can optionally be used with separators.

El diseño de estas mesas se caracteriza por poder combinar los colores de sus patas con sus pies reguladores de aluminio macizo pintado. Las mesas Fork están diseñadas para ser combinadas entre sí, con el añadido de poder usarlas con separadores de manera opcional.



Fork

FOORK

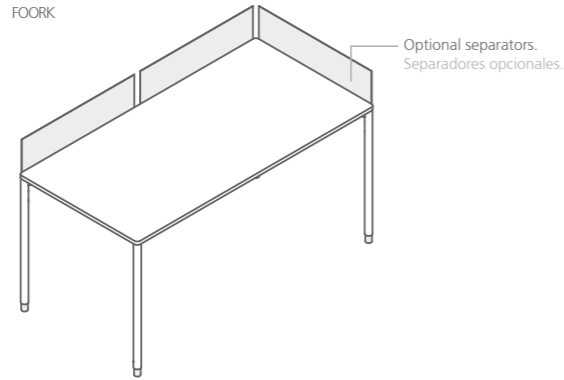

600x600
· 23.62" x 23.62"

750x750
· 29.52" x 29.52"

600x1200
· 23.62" x 47.24"

750x1500
· 29.52" x 59.05"

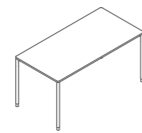
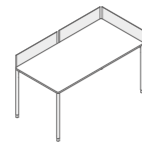

mm · inches

Designed
to be mixed
between them

Legs are combinable
with attractive and
functional
aluminum feet



by VÍCTOR CARRASCO

Víctor Carrasco, strategic director of Viccarbe, has developed and positioned international brands with remarkable added value, thanks to his passion for synthesis and sustainable growth.

Víctor Carrasco, director estratégico de Viccarbe, desarrolla y posiciona marcas internacionales con un sorprendente *added value* gracias a su fijación por la síntesis y los crecimientos sostenibles.



Fork by Víctor Carrasco

Naski

The solution your workspace needs!

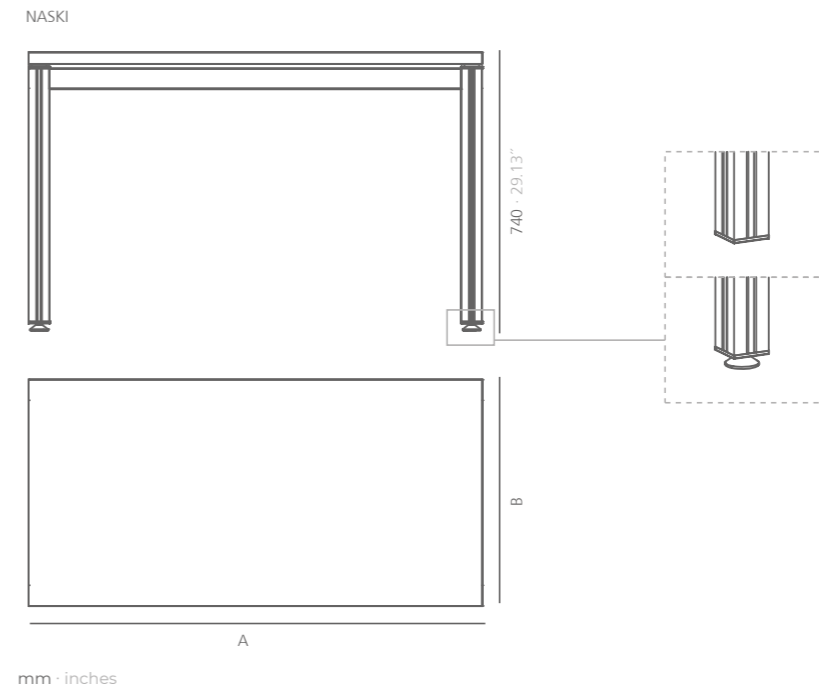

Very stable working tables with a lightweight aluminum structure. Two types of legs available. The tabletops can be soft melamine chipboard or compact HPL.

Mesas de trabajo muy estables y ligeras con estructura de aluminio. Disponibles dos versiones de patas. Los sobres de las mesas pueden ser de tablero aglomerado con acabado de melamina soft o compacto HPL.

Store

Personal auxiliary furniture, designed to optimize workspaces thanks to its functionality and mobility, thought-out to hold handbags, jackets, wallets, bags, phones, tablets, laptops, and any kind of personal items. Includes a magazine rack and a handle that facilitates its movement. An adapted shelf to support drinks and to hold up little objects is optional. Both complements can be hung on one side or another to improve the user ergonomics. Made of steel.

Mueble auxiliar personal diseñado para optimizar los espacios de trabajo por su funcionalidad y movilidad, pensado para contener bolso, chaqueta, cartera, mochila, móvil, tablet, portátil y cualquier tipo de objeto personal. Incluye un revistero y un tirador que facilita su desplazamiento. Se puede disponer de un estante adaptado para sostener bebidas y apoyar objetos pequeños. Ambos complementos pueden colocarse a un lado u otro del mueble para mejorar la ergonomía del usuario. Fabricado en plancha de acero.



Store

STORE

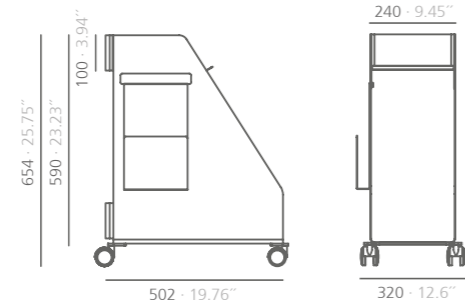

OPTIONAL · OPCIONAL

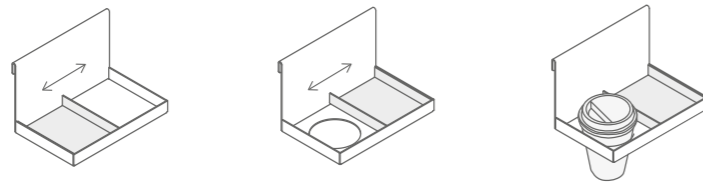
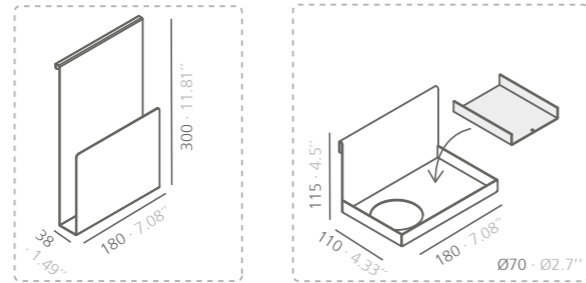

mm · inches



Optimize your workspace
You can change desk keeping your belongings with you

STC Studio is part of the product design and development department of Systemtronic, integrated by a group of professionals with a wide experience in the sector.

STC Studio forma parte del departamento de diseño y desarrollo de producto de Systemtronic, compuesto por un grupo de profesionales con amplia experiencia en el sector.

by STC STUDIO

Store by STC Studio

Take advantage of your space



SWIRE rectangular desktop
grommet metallic and lacquered
· pasacables rectangular
de sobremesa metálico y lacado

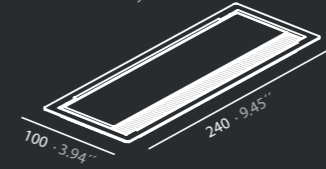

OMEGASTC metal grommet strip
· regleta pasacables metálica

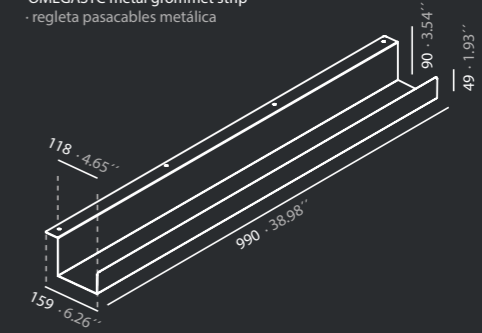

CPURD CPU support with casters
· soporte de CPU con ruedas

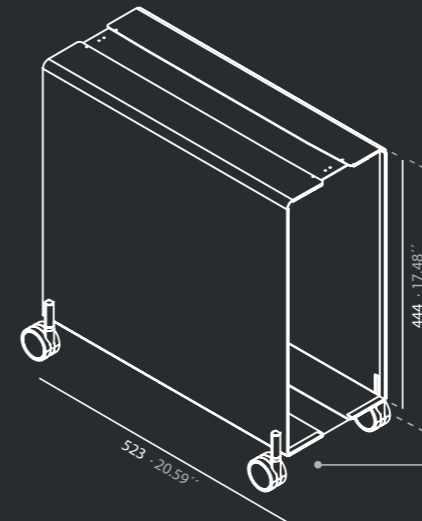

CPUSTC CPU hanging support
· soporte colgante de CPU

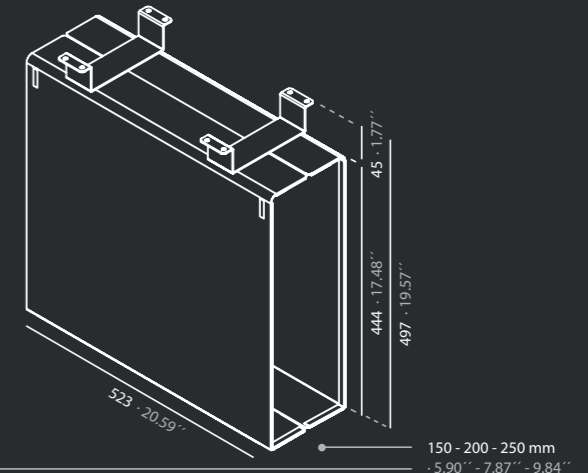

mm · inches

Set of accessories that allows the organization of office items in working spaces.

Serie de accesorios que permiten la organización de elementos de oficina en espacios de trabajo.

Office set

Wire

Organize your facilities

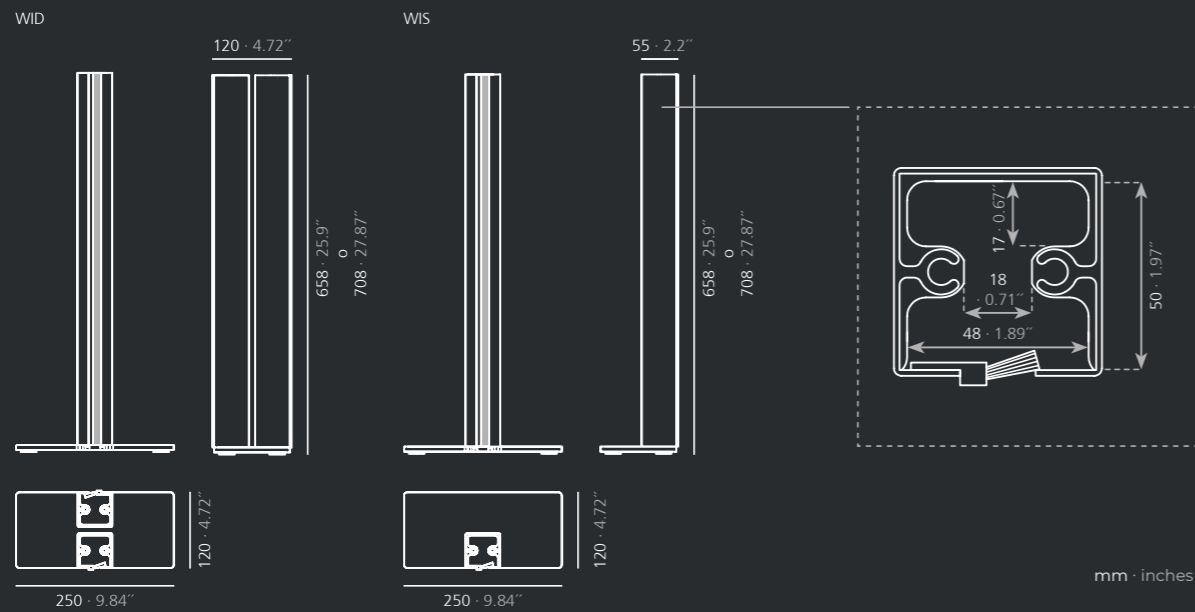

Freestanding aluminum column to hide cables, with two versions: single or double. It includes a black brush on its side that allows inserting and removing cables easily. Its base is designed for facilities with technical floors.

Column autoportante de aluminio para ocultar cables. Presenta dos versiones: sencilla o doble. Incluye un cepillo negro en el lateral que permite introducir y extraer cables fácilmente. Su base está diseñada para instalaciones con suelos técnicos.

Office set

Supp / Support

An ergonomic solution



SUPP



mm · inches

Computer screen support made of one steel sheet that allows to save the keyboard underneath.

Soporte para pantallas de ordenador fabricado con una única plancha de acero que permite guardar el teclado debajo.

SUPPORT

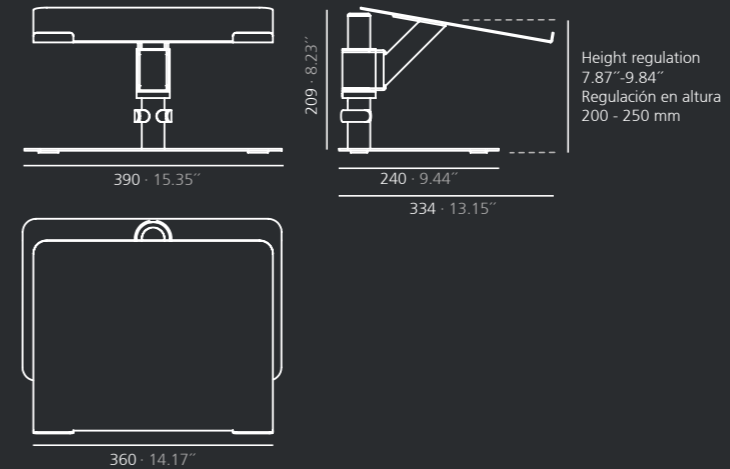

mm · inches

This laptop stand allows you to adopt an ergonomically correct posture while working.

Este soporte para ordenador portátil permite adoptar una postura ergonómicamente correcta durante el trabajo.

**It's up to you
what happens
now...**

remember

Our classics!

- Textured black
RAL 9011
- Textured white
- Textured anthracite gray
- White gloss
- Aluminum gloss
RAL 9006
- Matte white
RAL 9003
- Matte grey beige
RAL 1019
- Satin black
RAL 9011
- Mustard gloss
RAL 1012

New colors, new inspiration, new emotions

- Textured green
RAL 6009
- Textured red sirung
- Textured bronze bagana
- Textured blue
RAL 5011
- Textured garnet
RAL 3005
- Textured rust rame
- Textured red
RAL 3001

Other finishes!

Specific finishes by reference of the define product in the price list.
Acabados específicos por referencia de producto definidos en tarifa.

	Wood Beech wood		Leatherette cone pouf Off white		Metallic finishes Anodized aluminum
	Wood Matte oak		Leatherette cone pouf Black		Metallic finishes Sandblasted aluminum
			Leatherette cone pouf Beige		Metallic finishes Natural aluminum
			Leatherette cone pouf Red		Metallic finishes Chromed steel
					Metallic finishes Textured gold Karkar

	Screen fabric Light grey		Outdoor version: HPL tabletop White soft		Laquered MDF tabletop White		Nube clock finishes White
	Screen fabric Anthracite grey		Outdoor version: HPL tabletop Black soft		Laquered MDF tabletop Black		Nube clock finishes Black
	Tensabarrier tape Black		Mathacrylate White		Melamine chipboard tabletop White soft		Nube clock finishes Matte oak
	Tensabarrier tape Red		Mathacrylate Black		Melamine chipboard tabletop Black soft		
	Tensabarrier tape Blue		Mathacrylate Ice		Glass tabletop Tempered glass		

Indicative finishes. Acabados orientativos.

Quality

ASSOCIATED N°00320
AIDIMME  METAL-PROCESSING, FURNITURE, WOOD AND PACKAGING
TECHNOLOGY INSTITUTE

 Quality Controlled

 Systemtronic cares about the environment

This publication may not be reproduced in whole or in part in any manner whatsoever without the written permission of the publisher. All models are protected by international patent.

Credits

Esta publicación no puede ser reproducida en todo o en parte sin el permiso escrito del editor. Todos los modelos están protegidos mediante patente internacional.

Art direction
Isho Design

Editorial design
Isho Design

Photography
Teddy Hernández
Antonio Perpiñán

www.st-systemtronic.com
C/ del Mar 3 | Rafelbunyol
Valencia | Spain
Tel. +34 961 852 784
nacional@st-systemtronic.com
export@st-systemtronic.com
exportl@st-systemtronic.com

Printed in Abril 2022 - G1

