

# Cassina

713/714

Catalogue | Contemporanei

Year of production 1973

Tables with polished chromium plated steel frame. Crystal table, thickness 12 mm (0.5"), with bevelled edge under the top.

## Gallery

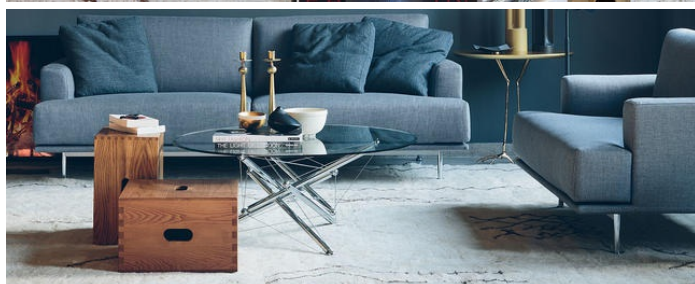
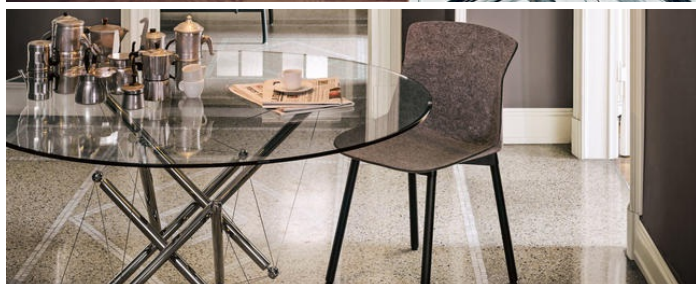
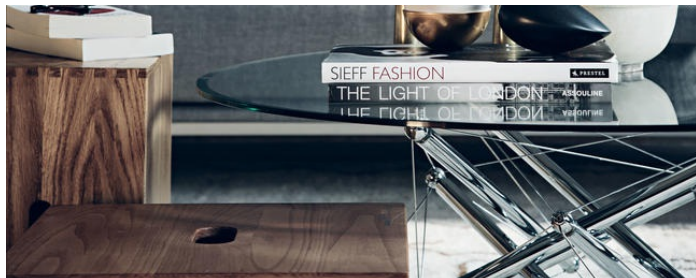

# Dimensions

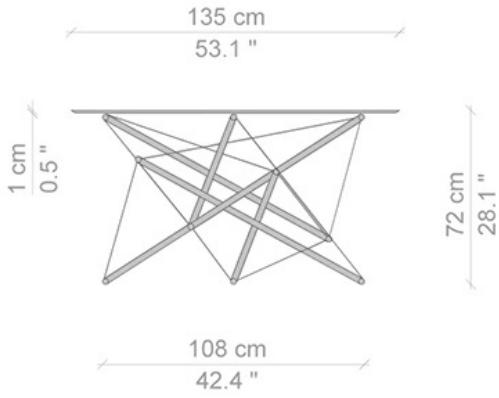
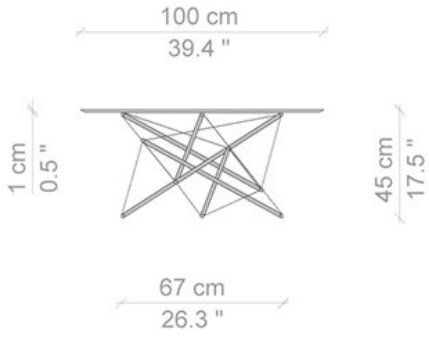

## Designer

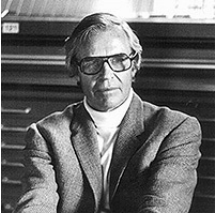

**Theodore Waddell**

After graduating in Chemistry (1950) and his Masters' in Business Administration in 1951 from Cornell, Theodore Waddell did his Master's in Architecture at the University of Pennsylvania (1964) and took a first in Architecture at Florence (1968). He practised as architect and industrial designer in Italy for fifteen years, making a name for himself also as photographer. He returned to the USA and set up practice in Santa Fe, New Mexico, where he now lives and works. Five of his lamps are to be seen in the Musée des Arts Decoratifs in Paris, and two are in the permanent collection at the MoMA in New York; this museum dedicated a special exhibition to him in 1969. The 713/714 Tensegrity tables designed for Cassina have been in the catalogue since 1972.