

Cassina

526 NUAGE

Family **PERRIAND**

Catalogue | **Maestri**

Year of design **1952 / 1956**

Year of production **2012**

Cutting-edge modularity: Nuage, a family of bookcases and storage units designed by Charlotte Perriand for Cassina.

Charlotte Perriand never sees modularity, the key to modern design, as rigid or aseptic. For her it always combines functionality and aesthetics, managing to completely satisfy user requirements.

The compositions for this model range from sideboards, to storage units, freestanding and wall-mounted bookcases, fixed symmetrically or asymmetrically, to self-supporting bookcases for using in the middle of rooms, in natural oak or black oak veneer.

The modules can be fitted with doors to close the open compartments, in anodised aluminium or in a wide range of colours, to create alternating hollows and solids.

Gallery



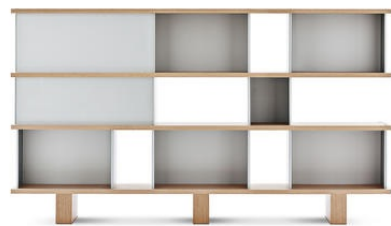
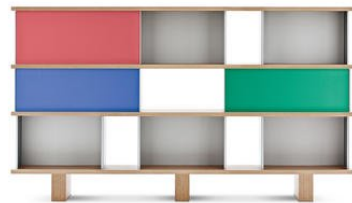
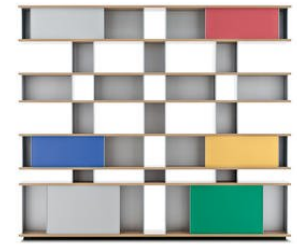
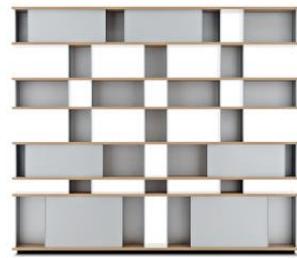
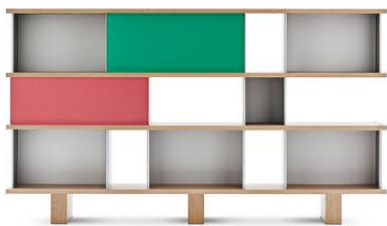
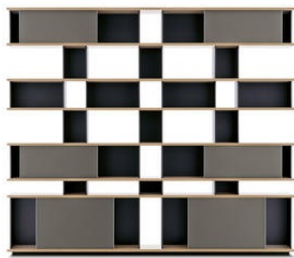
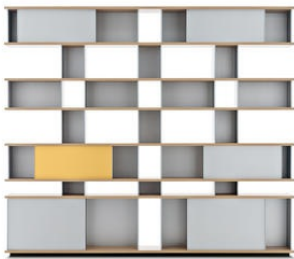

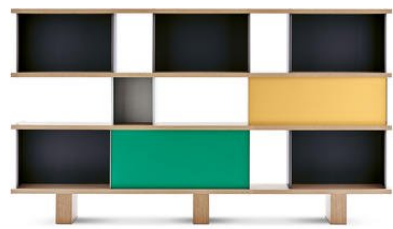
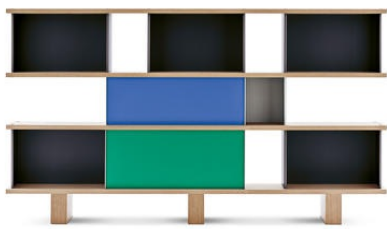
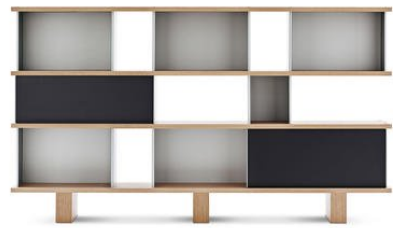
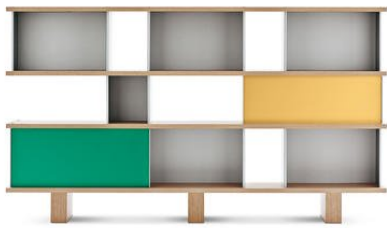
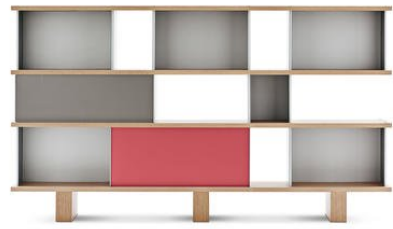
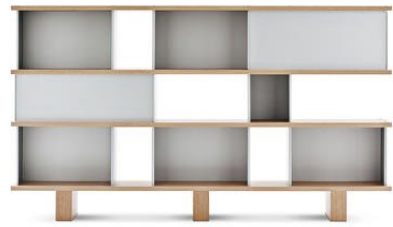
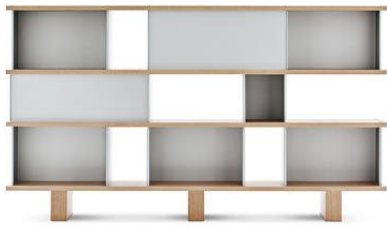

Dimensions

36 cm 65 cm
14.2" 25.7"

51 cm
20.1"

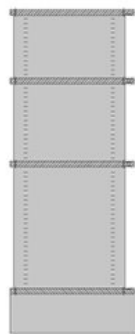
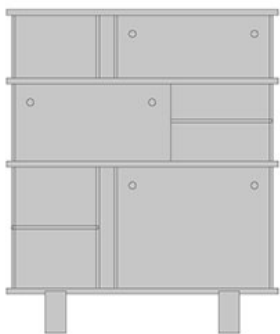

50 cm 32 cm 26 cm
19.7" 12.6" 10.1"

133 cm
52.4"

112 cm
44.0"

52 cm
20.6"

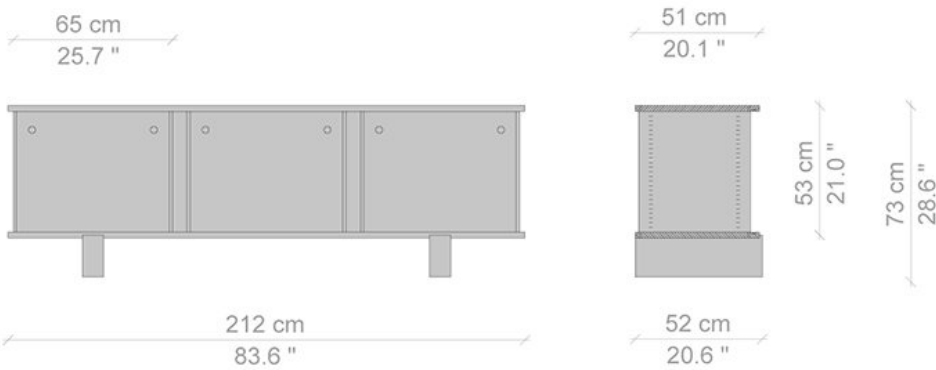
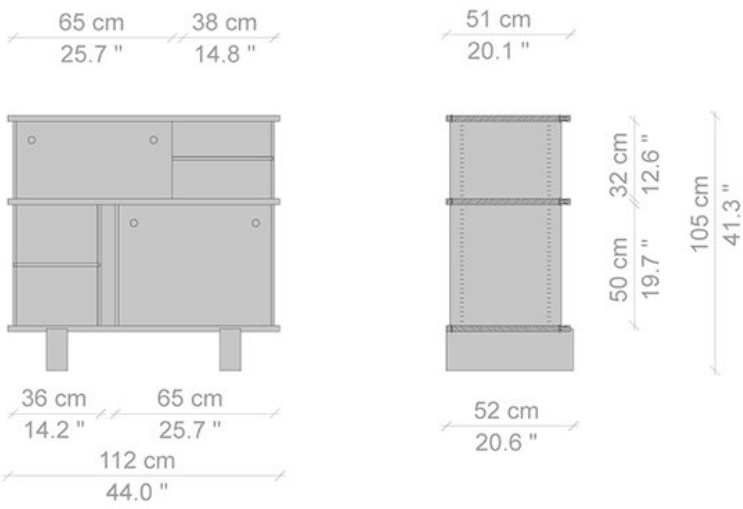
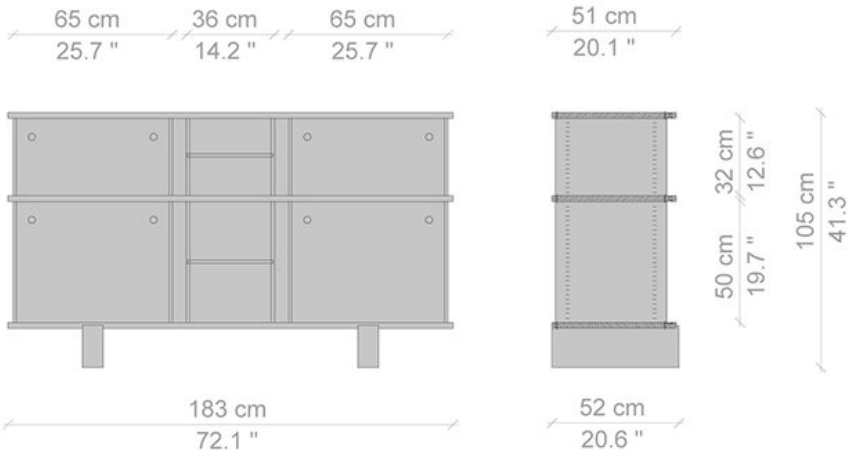

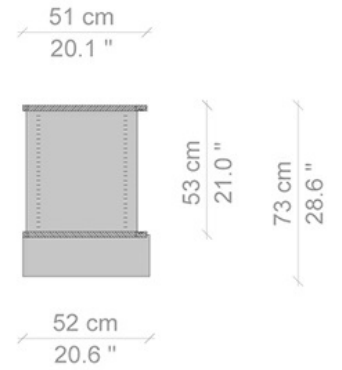
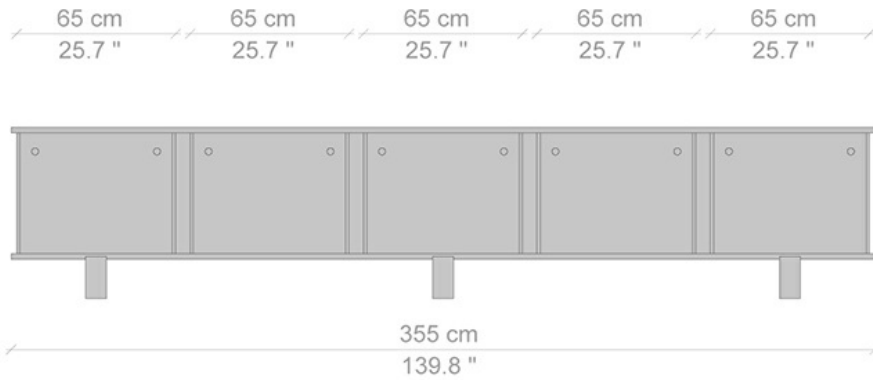
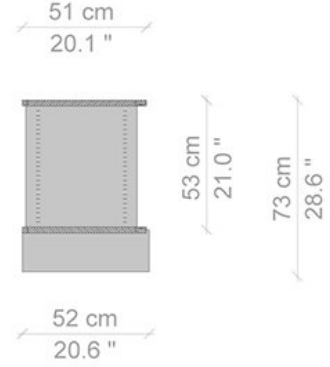
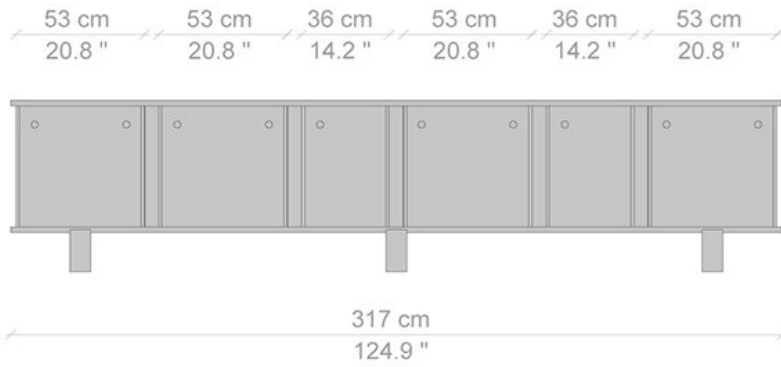
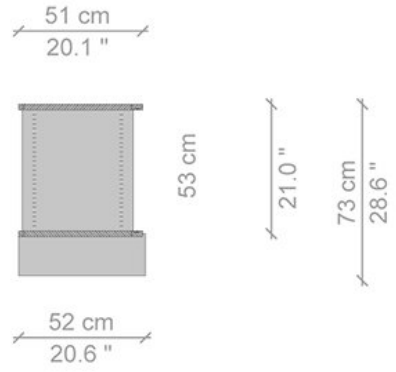
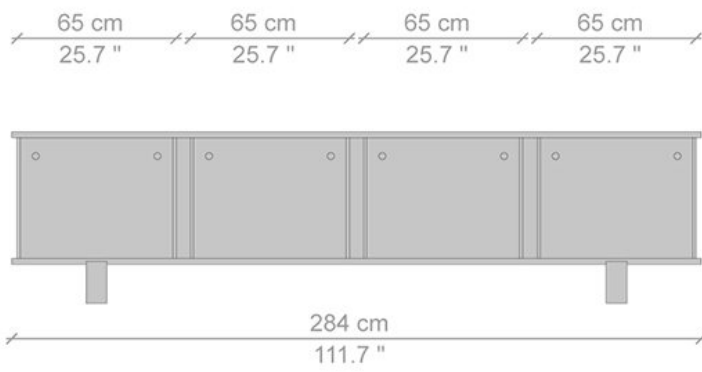

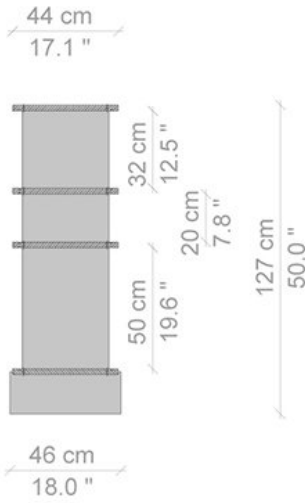
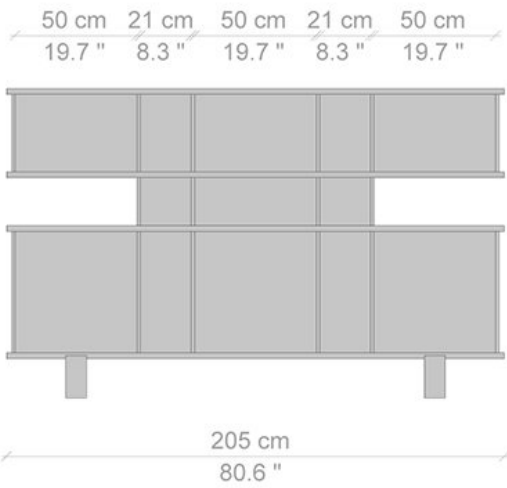
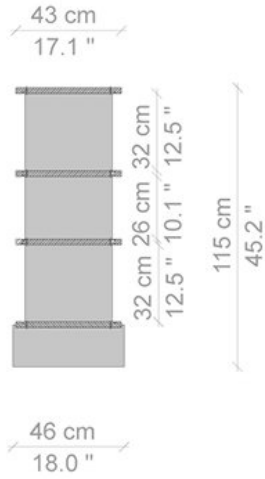
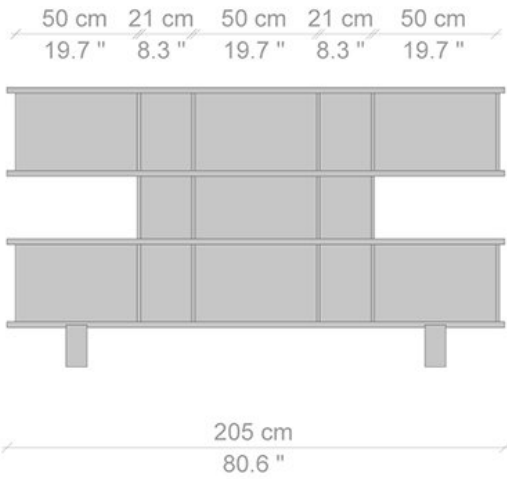

50 cm 21 cm 50 cm 21 cm 50 cm
19.7" 8.3" 19.7" 8.3" 19.7"

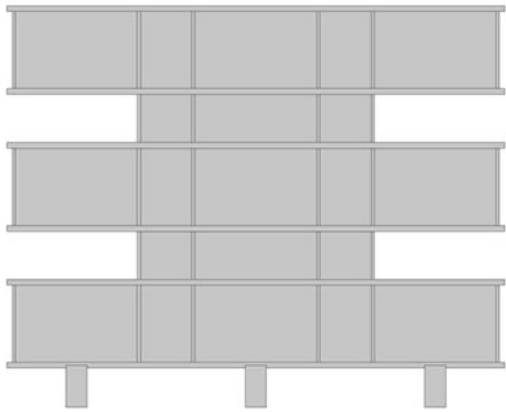

205 cm
80.6"

43 cm
17.1"

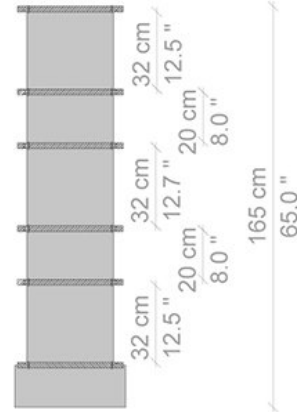

46 cm
18.0"

52 cm 22 cm 52 cm 22 cm 52 cm
20.6" 8.6" 20.6" 8.6" 20.6"

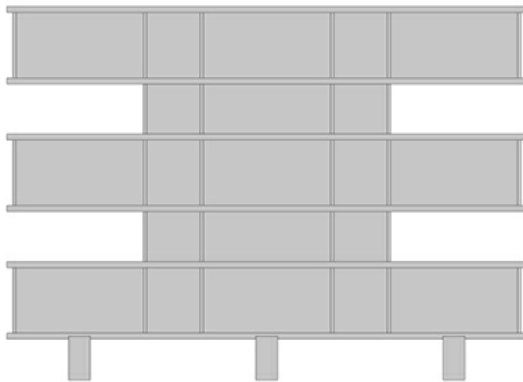

213 cm
84.0"

46 cm
18.0"

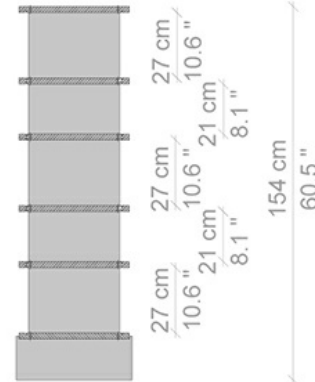

48 cm
18.8"

50 cm 21 cm 50 cm 21 cm 50 cm 21 cm 50 cm
 19.7" 8.3" 19.7" 8.3" 19.7" 8.3" 19.7"

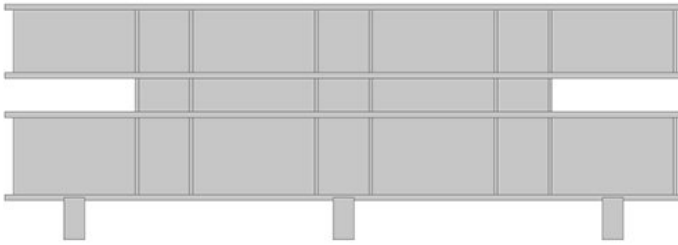

278 cm
 109.6"

43 cm
 17.1"

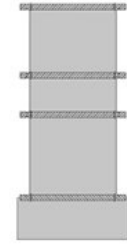

46 cm
 18.0"

26 cm
 10.2"
 32 cm
 12.5"
 16 cm
 6.4"
 97 cm
 38.2"

50 cm 21 cm 50 cm 21 cm 50 cm 21 cm 50 cm
 19.7" 8.3" 19.7" 8.3" 19.7" 8.3" 19.7"

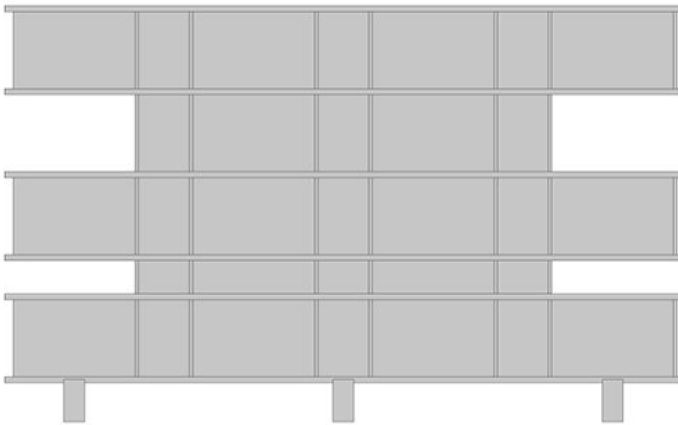

278 cm
 109.6"

43 cm
 17.1"



46 cm
 18.0"

32 cm
 12.5"
 32 cm
 12.5"
 32 cm
 12.5"
 14 cm
 5.4"
 171 cm
 67.5"

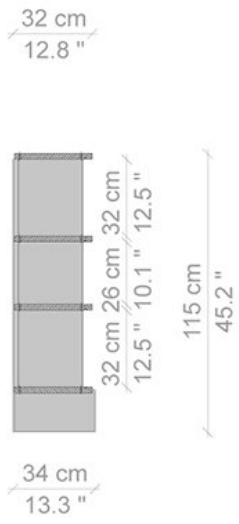
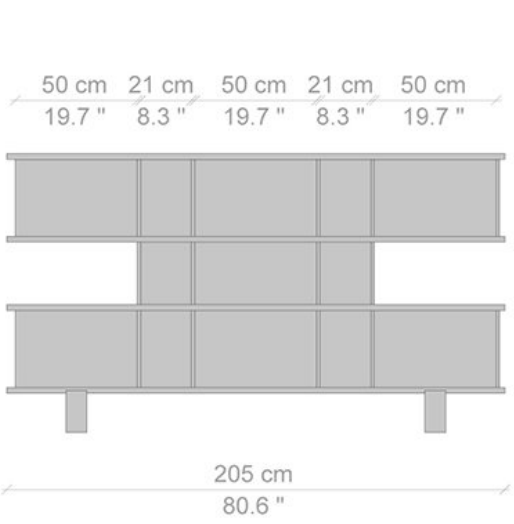
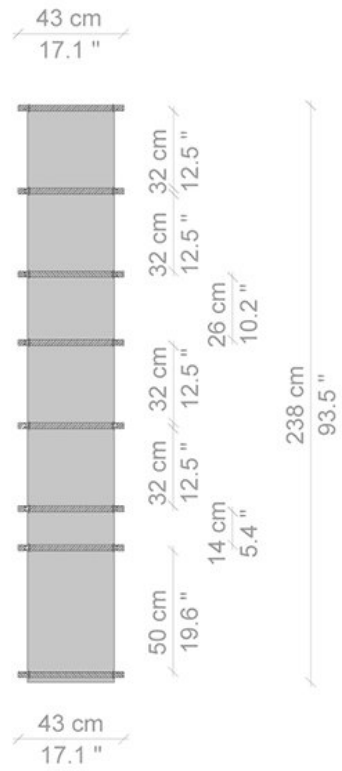
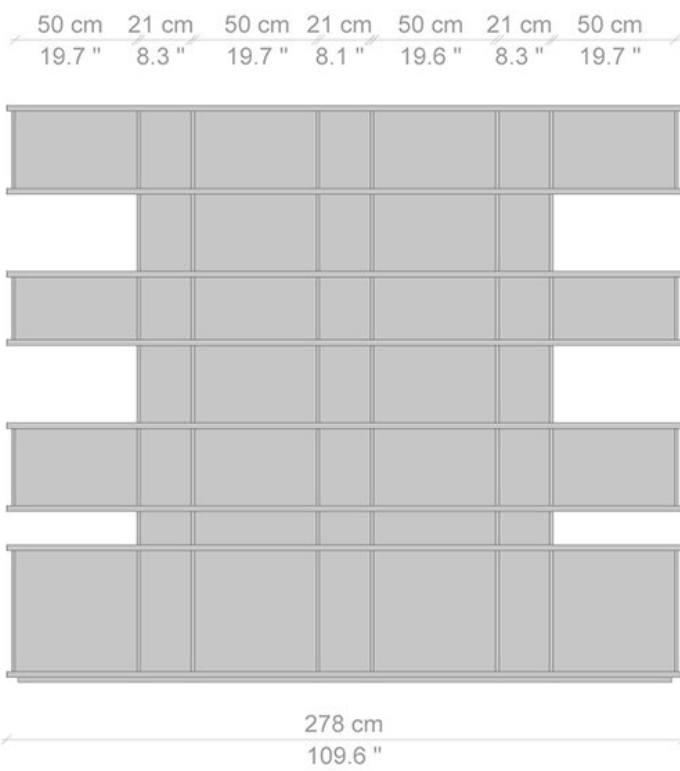

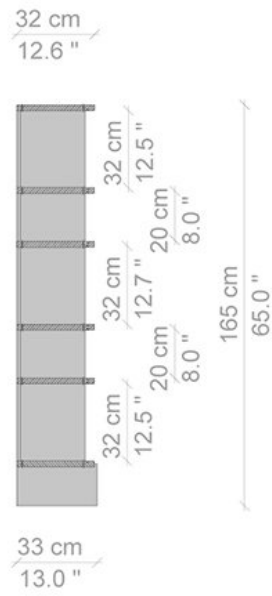
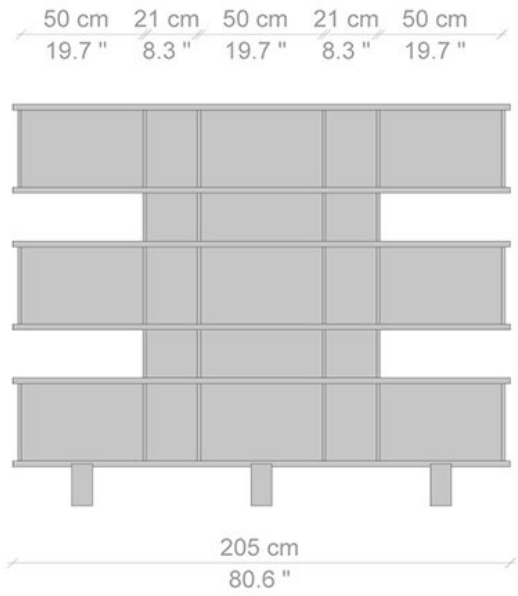
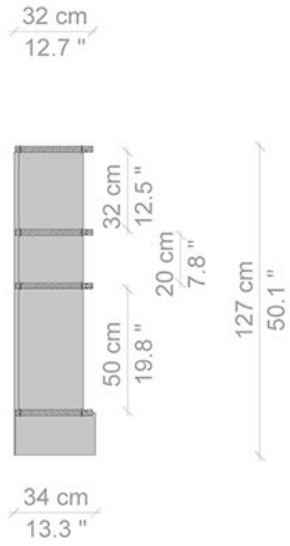
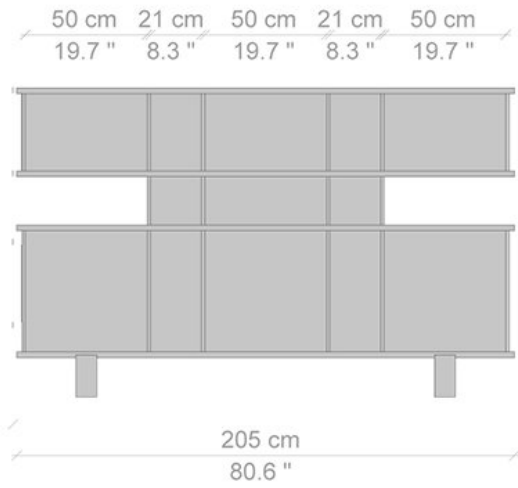

52 cm 22 cm 52 cm 22 cm 52 cm
 20.6" 8.6" 20.6" 8.6" 20.6"

33 cm
 13.1"

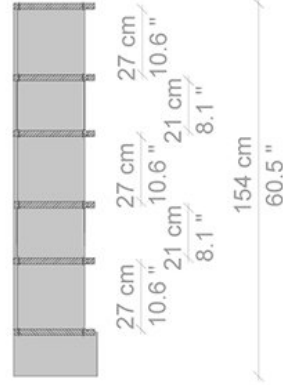
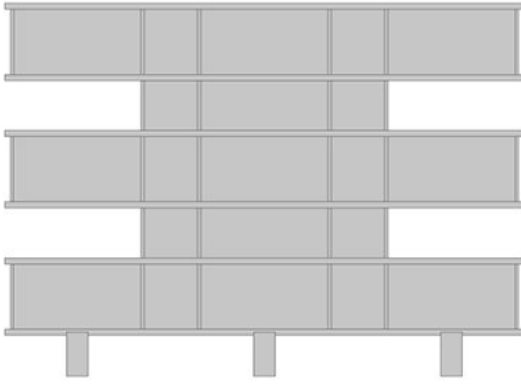

213 cm
 84.0"

35 cm
 13.6"

50 cm 21 cm 50 cm 21 cm 50 cm 21 cm 50 cm
 19.7" 8.3" 19.7" 8.3" 19.7" 8.3" 19.7"

32 cm
 12.6"

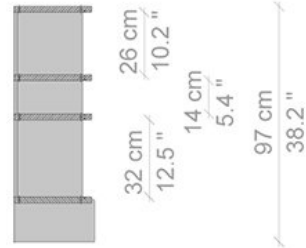
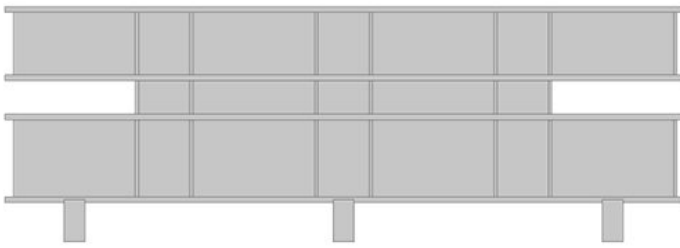

278 cm
 109.6"

33 cm
 13.1"

50 cm 21 cm 50 cm 21 cm 50 cm 21 cm 50 cm
 19.7" 8.3" 19.7" 8.3" 19.7" 8.3" 19.7"

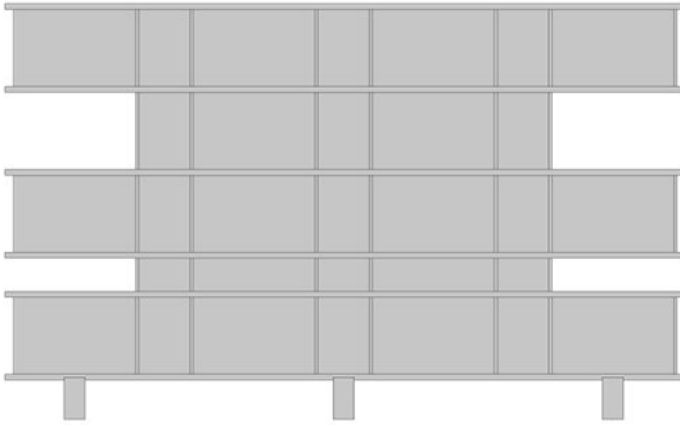

278 cm
 109.6"

32 cm
 12.6"

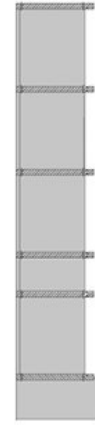

33 cm
 13.1"

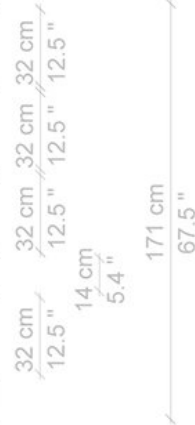

171 cm
 67.5"

50 cm 21 cm 50 cm 21 cm 50 cm 21 cm 50 cm
 19.7" 8.3" 19.7" 8.1" 19.6" 8.3" 19.7"

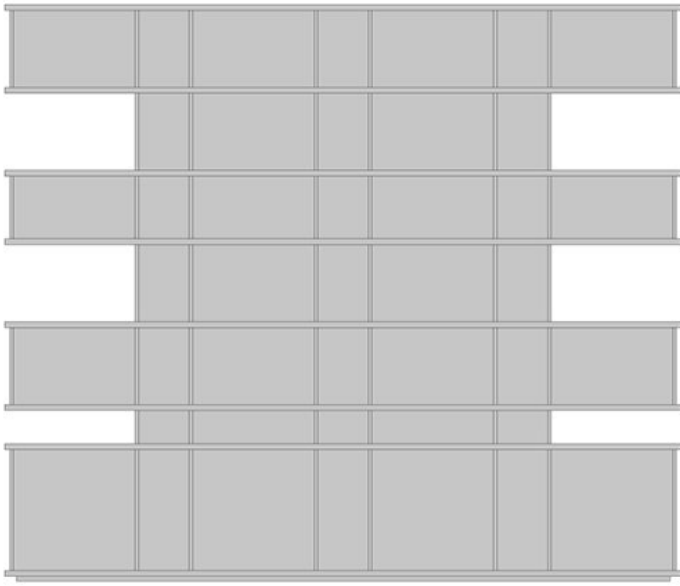

278 cm
 109.6"

32 cm
 12.6"

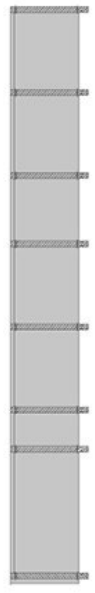

32 cm
 12.6"



238 cm
 93.6"

21 cm 66 cm 21 cm
8.3" 25.8" 8.3"

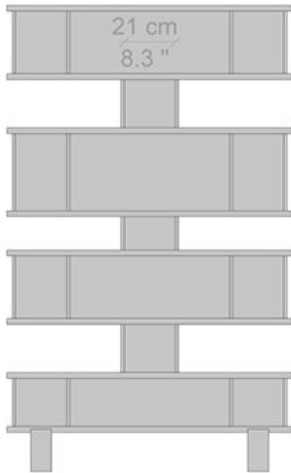

117 cm
46.2"

32 cm
12.6"

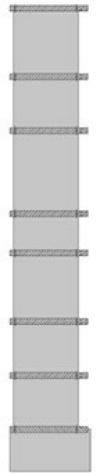

26 cm 10.1"
32 cm 12.5"
26 cm 10.1"
20 cm 7.8"
20 cm 7.8"

192 cm
75.4"

33 cm
13.0"

21 cm 90 cm 21 cm
8.3" 35.6" 8.3"

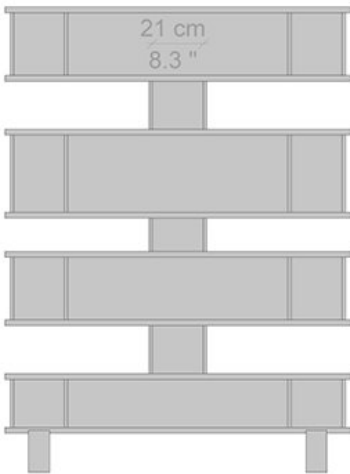

21 cm
8.3"

32 cm
12.6"

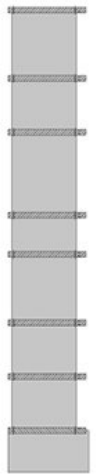

26 cm 10.1"
32 cm 12.5"
26 cm 10.1"
20 cm 7.8"
20 cm 7.8"

192 cm
75.4"

33 cm
13.0"

21 cm 66 cm 21 cm 66 cm 21 cm
 8.3" 25.8" 8.3" 25.8" 8.3"

32 cm
 12.6"

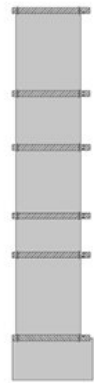
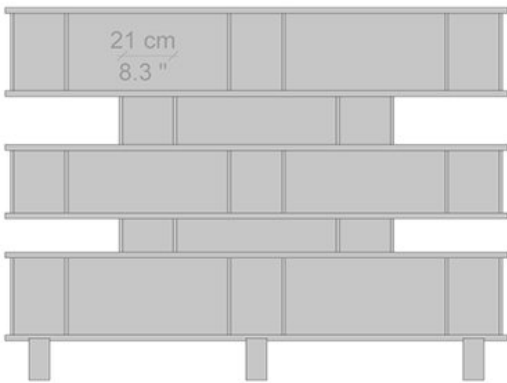

32 cm 32 cm
 12.5" 12.5"
 26 cm 20 cm
 10.1" 7.8"
 14 cm
 5.4"
 153 cm
 60.3"

33 cm
 13.0"

21 cm 66 cm 21 cm 66 cm 21 cm 66 cm 21 cm
 8.3" 25.8" 8.3" 25.8" 8.3" 25.8" 8.3"

32 cm
 12.6"

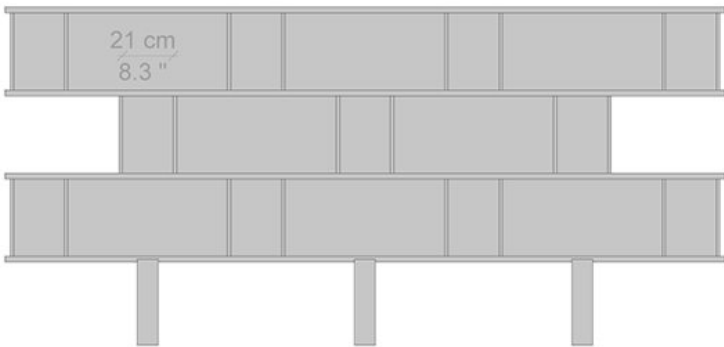

32 cm 32 cm
 12.5" 12.5"
 32 cm
 12.5"
 139 cm
 54.7"

33 cm
 13.0"

21 cm 66 cm 21 cm 66 cm 21 cm 66 cm 21 cm
 8.3" 25.8" 8.3" 25.8" 8.3" 25.8" 8.3"

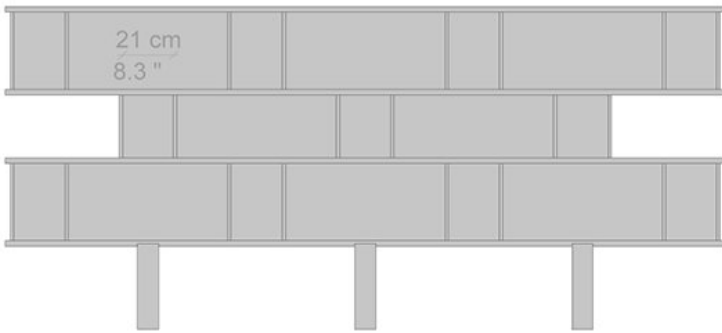

32 cm
12.6"

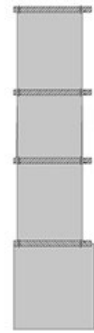

32 cm 26 cm 32 cm
12.5" 10.2" 12.5"

133 cm
52.4"

33 cm
13.0"

27 cm 84 cm 27 cm 84 cm 27 cm
10.7" 33.2" 10.7" 33.2" 10.7"

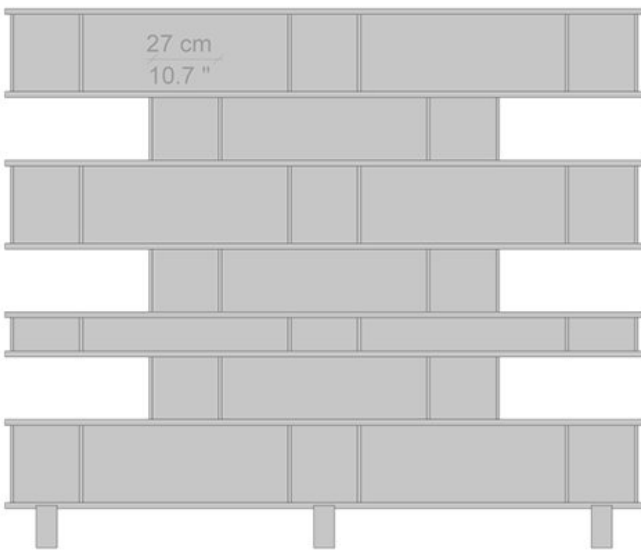

32 cm
12.6"

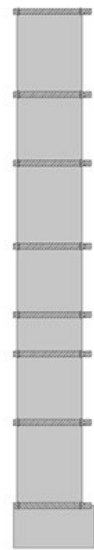

32 cm 26 cm 32 cm 26 cm 32 cm
12.5" 10.1" 12.5" 10.1" 12.5"

14 cm
5.4"

222 cm
87.3"

33 cm
13.0"

21 cm 66 cm 21 cm 66 cm 21 cm 66 cm 21 cm
 8.3" 25.8" 8.3" 25.8" 8.3" 25.8" 8.3"

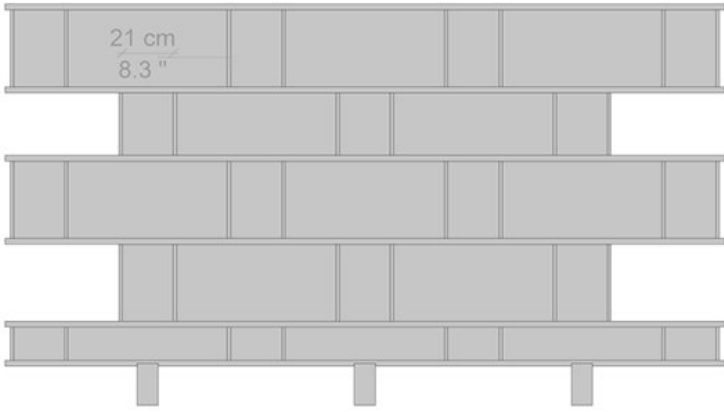

32 cm
 12.6"



32 cm 32 cm 26 cm 32 cm
 12.5" 12.5" 10.2" 12.5"
 14 cm
 5.4"
 165 cm
 65.1"

33 cm
 13.0"

21 cm 66 cm 21 cm 66 cm 21 cm 66 cm 21 cm
 8.3" 25.8" 8.3" 25.8" 8.3" 25.8" 8.3"

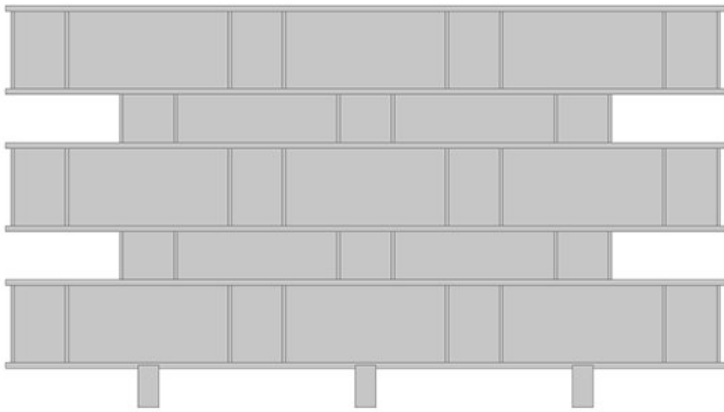

32 cm
 12.6"



20 cm 32 cm 20 cm 32 cm
 7.8" 12.5" 7.8" 12.5"
 32 cm
 12.5"
 165 cm
 65.1"

33 cm
 13.0"

21 cm 66 cm 21 cm 66 cm 21 cm 66 cm 21 cm
 8.3" 25.8" 8.3" 25.8" 8.3" 25.8" 8.3"

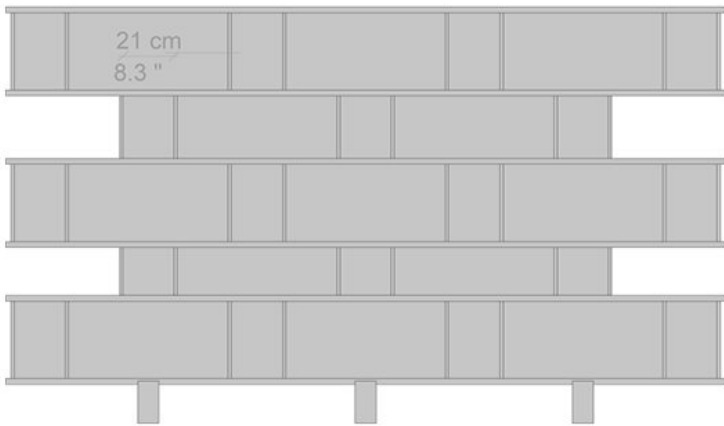

32 cm
12.6"

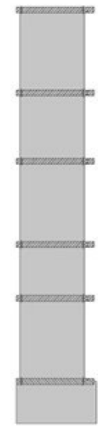

33 cm
13.0"

33 cm 68 cm 33 cm
13.1" 26.8" 13.1"

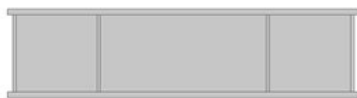

32 cm
12.6"



145 cm
57.0"

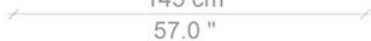

33 cm 68 cm 33 cm 68 cm 33 cm
13.1 " 26.8 " 13.1 " 26.8 " 13.1 "



32 cm
12.6 "



37 cm
14.4 "

249 cm
98.0 "

21 cm 110 cm 21 cm
8.3 " 43.4 " 8.3 "

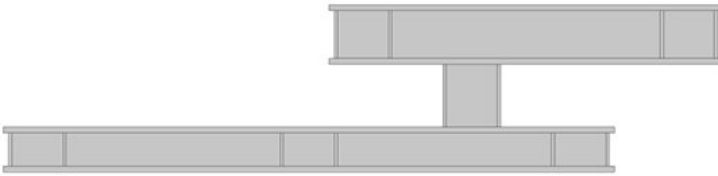

20 cm 7.8 "
14 cm 5.4 "

26 cm 10.1 "

69 cm 27.1 "

21 cm 88 cm
8.3 " 34.7 "

296 cm
116.6 "

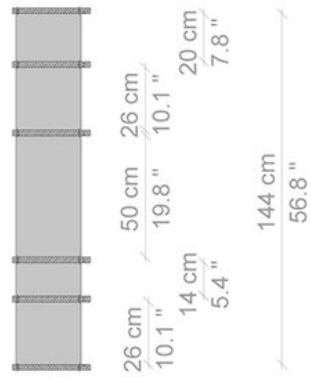
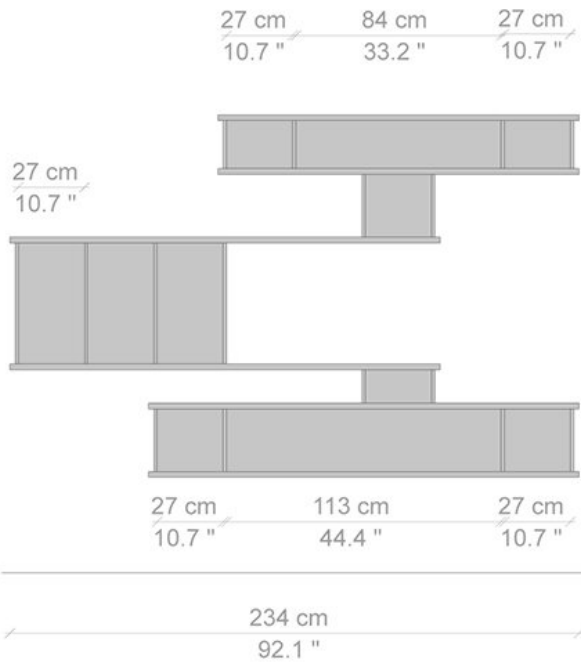

Designer



Charlotte Perriand

Charlotte Perriand full membership of that avant-garde cultural movement which, from the first decades of the twentieth century, brought about a profound change in aesthetic values and gave birth to a truly modern sensitivity towards everyday life. In this context, her specific contribution focuses on interior composition, conceived as creating a new way of living, still today at the heart of contemporary lifestyle.

In the sphere of twentieth century furnishing history, the advent of modernity made possible the entrepreneurial audacity of this true reformer of interior design. At the beginning of her professional career she was acclaimed by critics for her Bar under the roof, exhibited at the Salon d'Automne in 1927 and constructed entirely in nickel-plated copper and anodized aluminium. In the same year, when she was just twenty-four years old, she began a decade-long collaboration with Le Corbusier and Pierre Jeanneret, at the famous design studios at 35, rue de Sèvres in Paris.

Her presence in the Le Corbusier studio is visible in all the furnishings designed with him and with Pierre Jeanneret: and so Charlotte Perriand becomes a cornerstone in the reformation project promoted by the architect, adding a distinct dimension of humaneness to the often cold rationalism of Le Corbusier. In her creations she manages to animate the fundamental substance of daily life with new aesthetic values: in particular her talent and intuition in the discovery and use of new materials manifest themselves to their full extent.

The ten-year long collaboration with Le Corbusier and Pierre Jeanneret, and her Japanese experience, represent periods of intense creative effervescence in the life of the artist. During her long stay in the Far East ('40-'46), she reveals her artistic talent to the full, through a reinterpretation of the reality of life to echo both tradition and modernity. By way of example, worthy of mention are the furnishings produced using traditional bamboo processing techniques, capable of enhancing the new forms already experimented using steel-tubing.

After her work as a professional, she concentrates on a series of original and balanced productions, commissioned by top-level authorities and leading companies of the calibre of Air France, and by a number of foreign organizations, authenticating the fame she had by now gained on the international scene.

The distinguishing factor of Charlotte Perriand's personality is a sincere loyalty to the principles of humane and innovative rationalism, preserved intact in her projects, on which she worked with such passion, also in readiness for their revival in the "Cassina I Maestri" collection.